

Operation manual

Ride on Brush Mower

Rabbit Mower

RM 9 8 3 F
(4WD)



0347-70400



- Before using the product, be sure to read and fully understand the important danger parts appearing in the text of the instruction manual.
- When purchasing this product, please ask your dealer for safety precautions.
- Keep this instruction manual in a safe place so that you can refer to it at any time.
- In order to maintain safety, please take an annual inspection according to the periodic inspection table in this manual.
- Be sure to use genuine products from the manufacturer for maintenance of this product.

//// OREC

Index

Item	Page
«Introduction»	1
«Definition and symbol mark»	1
«Regulation of this product»	2
«Important Notices»	2
«Warranty / Contract / Disclaimer» ..	2
1. Before using (Please read carefully for safe use)	
1.1 working conditions.....	4
1.2 Before Working	4
1.2.1 Precautions before work	4
1.2.2 Inspection before work	5
1.2.3 No fires • Fuel supply.....	6
1.3 During work.....	6
1.3.1 Precautions of while working...	6
1.3.2 Operational precautions	7
1.3.3 Inspection while working • stop • cleaning	7
1.4 Notes on loading and unloading	8
1.5 Inspection / maintenance	8
1.6 Storage	9
1.7 Warning display mark.....	9
2. Names and Functions of each part	
2.1 Name of each part	14
2.2 Function of each part	15
① Engine switch.....	15
② Throttle Lever	15
③ Choke lever.....	15
④ Light Switch	15
⑤ Cutting Height Adjustment.....	15
⑥ Blade clutch lever	16
⑦ Change pedal • Speed Shift lever.....	16
⑧ Driving clutch lever	16
⑨ Differential lock lever	17
⑩ Parking brake pedal	17
⑪ Blade replacement cover	17
⑫ Seat (Seat slide and Seat suspension functions Equipped.).....	18
⑬ Handle tilt lock lever	18
⑭ Fuse box.....	18
⑮ inclinometer.....	18
⑯ Engine oil warning light	19
⑰ Pilot lamp	19
⑱ Hour meter	19
2.3 Direction of definition	19
3. Inspection before work	
3.1 Check engine oil	20
3.2 Fuel inspection and refueling	21
4. Operation and work	
4.1 Starting and stopping the engine ...	23
4.1.1 How to start the engine	19
4.1.2 How to stop the engine	25
4.2 Driving, Speed change, Turning and Stopping.....	26
4.2.1 How to drive	26
4.2.2 How to stop (park).....	27
4.2.3 How to operate the differential lock lever	28
4.2.4 How to move when it cannot run.....	28
4.3 Loading and unloading, Transportation.	29
4.3.1 loading and unloading.....	30
4.4 How to do the good work	31
4.4.1 How to do the mowing work ..	32
4.5 Adjusting the handle and seat position	35
4.6 How to use the moving light	35
5. Inspection / maintenance / adjustment	
5.1 Oil inspection / replacement / lubrication.....	35
5.1.1 Inspection and replacement of mission oil.....	35
5.1.2 Engine Oil check and change .	36
5.1.3 Oil filter replacement	37
5.1.4 HST oil check and change	37
5.1.5 lubrication for each part.....	39
5.2 Engine related part cleaning, inspection, and adjustment ...	40
5.2.1 Cleaning the air cleaner	40
5.2.2 Checking and adjusting the spark plug.....	41
5.2.3 Check the fuel pipe.....	41
5.2.4 Check the fuel filter	42
5.2.5 How to clean the engine cooling system.....	42
5.2.6 How to clean the engine exhaust system	43
5.3 Product Inspection and adjustment.	43
5.3.1 Wire / belt adjustment for each part.....	44
① Drive belt adjustment.....	44
② Blade belt adjustment (under seat bracket)	45
③ Adjusting the belt retainer (under the seat bracket)	45
④ Blade brake adjustment.....	46
⑤ Parking brake adjustment	46
⑥ Adjusting the Speed shift lever .	47

- ⑦ Blade clutch wire adjustment... 47
- ⑧ Diff-lock wire adjustment 47
- ⑨ Safety switch adjustment 48
- 5.3.2 Tire Air pressure Adjustment 49
- 5.3.3 Front tire inspection 49
- 5.4 Inspection, replacement, and installation of Blade. 50

- 5.4.1 How to open and close the Blade replacement cover 51
- 5.4.2 Check and Replace Blade 52
- 5.4.3 How to replace the Blade 53
- 5.5 Long-term storage..... 54
- 5.5.1 Preparation for long-term storage 54

6. attached list

- 6.1 Specification sheet 56
- 6.2 Tool bag details..... 57
- 6.3 Consumable item details 57

7. check list

- 7.1 Periodic inspection table
- 7.2 Engine malfunction and how to deal with it.
- 7.3 Self-diagnosis table.
- 7.4 Battery maintenance/inspection.
 - 7.4.1 How to replenish the battery fluid.
 - 7.4.2 How to auxiliary charge.
 - 7.4.3 Battery life.
 - 7.4.4 Battery failure and how to deal with it.
 - 7.4.5 Treatment method in case of accident with electrolyte.
 - 7.4.6 Estimated battery charging time.

■ Regarding to the instruction manual.



- Please read this instruction manual carefully before using this machine.
- When lending or transferring this unit, be sure to hand it along with this unit.
- If lost or damaged, please order directly to the dealer shop.

《Introduction》

- ✓ Thank you for purchasing this product.
- ✓ This instruction manual describes the correct handling method and easy maintenance method so that the product can be kept in the best condition at all times for safe operation.
- ✓ Before using the product, be sure to read this instruction manual carefully to fully understand the safe operation work and correct handling method, and use it for safe and efficient work.
- ✓ After reading the manual, keep it in a safe place for future reference so that you can use this product for a long time.

《Definition and symbol mark》

In this manual, the following definitions and symbols are used according to the degree of danger (or the magnitude of the accident). Please fully understand the meanings of the following symbols and follow their contents.

Symbol mark	Definition
 Danger	Indicates what could result in death or serious injury if this Danger sign is not followed.
 Warning	Indicates a hazard that could result in death or serious injury if the warning is not followed.
 Caution	Indicates a risk of injury if the Caution is not followed. It also indicates what can cause damage to the product itself if not followed or corrected.
Reference	This section describes the performance of the product that you should know about operation and maintenance, and items that are easy to make mistakes.

《Regulation of this product》

- 1) This product has been developed as an agricultural machine, so please do not use it for any other purpose (use such as rental that the operator cannot identify).
- 2) Grasses such as ivy and vines that crawl along the ground may not be able to be cut.
- 3) This machine has one passenger capacity. In addition, it is not possible to drive on a road or a place that is used for general traffic (agricultural road, forest road, public plaza, etc.). Even if you get a vehicle number, you cannot drive on public roads.

《Important Notices》

- 1) Please note that the specifications of your product and the contents of this document may not match in some cases due to changes in parts etc. due to performance / durability improvement and other specification changes.
- 2) Please note that copying all or part of the contents of this document without permission is a violation of copyright, unless otherwise required by law.
- 3) In this manual, photographs and illustrations are used so that the explanation part can be understood concretely, but there are cases where the parts other than the explanation part are omitted.

《Warranty / Contract / Disclaimer》

- 1) The warranty period of this product is one year from the time of purchase of a new product, or 50 usage hours (6 months of contract work, or 50 usage hours), whichever comes first.
- 2) It is impossible to predict all precautions. When using the product, it is necessary for the operator to pay attention to safety.
- 3) It is impossible to predict all precautions. When using the product, it is necessary for the worker to pay attention to safety.
- 4) If you do not understand even after reading this manual, do not operate any arbitrary operations, and be sure to consult with the store where you purchased the product.
- 5) Regular inspection and maintenance are indispensable in order to continue to use the product

safely and efficiently. Please make a regular inspection and maintenance. The warranty does not cover failures or accidents resulting from failure to perform these inspections / maintenances, non-compliance with this manual, such as use or modification beyond specifications.

- 6) The supply period (term) of repair parts for this product will be 9 years after the production is discontinued. However, we may contact you regarding the delivery date of special parts even within the supply period.
- 7) If you have any questions or services, please contact your dealer. In that case, please refer to the following section and check "Product model number, serial number, and model name of installed engine and contact us as well.

"serial number" of this machine

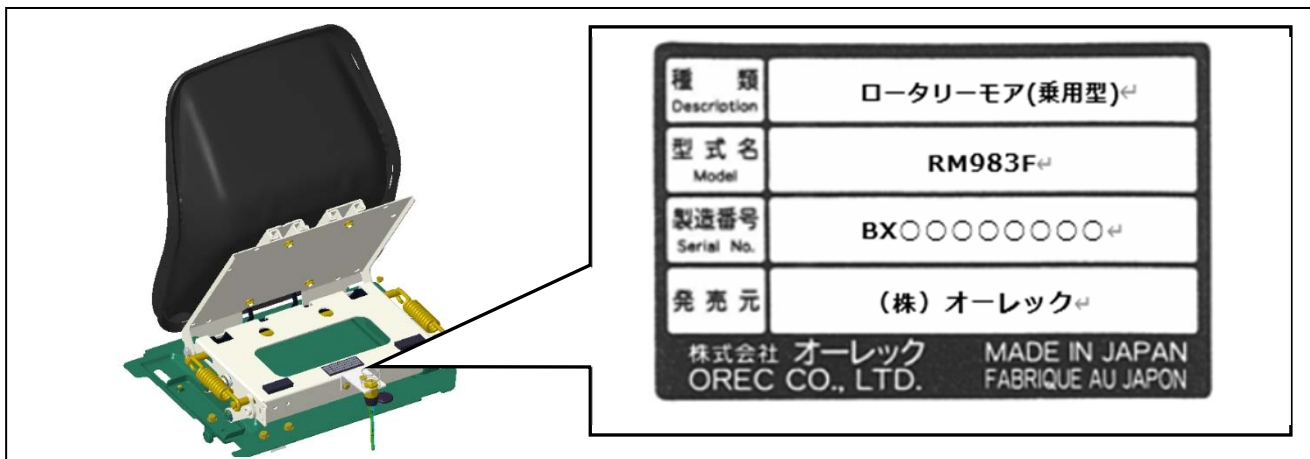

1. Before using ‹Please read carefully for safe use›

1.1 working conditions

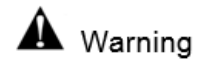

Warning

- 1) Please do not use those who cannot understand the contents of this book.
This product is a one-seater. Please do not carry people other than worker.
- 2) When lending a machine to another person, please explain the handling method and instruct them to work after understanding it fully.
- 3) Do not work when normal driving operation cannot be performed due to overwork, illness, drugs or other influences.
- 4) Do not let work to drinking person, pregnant women, children or unskilled workers.
- 5) To avoid getting caught in the rotating part of the machine, wear long sleeve pants and long sleeve outerwear, wear suitable clothing for works.
Tobacco and rolled towels are strictly prohibited
- 6) For each product, please use stable equipment such as safety shoes (boots), helmets (hats) , anti-slip shoes (spikes), eyeglasses, gloves, snake pad for protect your body.
- 7) This product has not been certified by the Road Transport Vehicle Act, so please never drive on public roads. We are not responsible for any accidents or violations caused by driving on the road.

1.2 Before Working

1.2.1 Precautions before work

- 1) Carbon monoxide poisoning may be caused by exhaust gas. Do not operate or work in places such as indoors where ventilation is inadequate.



Danger



Warning

- 1) Never modify this machine to become an impediment to safety work.
‹We are not responsible for any accidents caused by these remodeling or defects.›
- 2) Please make sure there are no tangible assets such as people, animals, vehicles and equipment, buildings, etc. in the surrounding area. Also, please check the safety of surroundings and start work. Do not approach dangerous places such as obstacles, gutters, soft shoulders, etc. in the field with set a marking etc.
- 3) Remove stones and other foreign objects in advance, and if there are obstacles that cannot be removed, install a caution sign or a safety fence that indicates the prohibited area, and then start work. In addition, in such a field, for the safety, work at a higher cutting than usual. It is dangerous because the Blade may be chipped or foreign matter such as stones may scatter.

- 4) When traveling on a river, cliff, or a step (road shoulder) to prevent falling, please run on a sufficiently safe flat place.
- 5) It is dangerous to use it in poor visibility when it is dark. Please do not use when place condition cannot be grasped sufficiently.



Caution

- 1) Do not use this machine in the rain or in a pool of water where it may be exposed to a large amount of water.
- 2) Be aware to other climatic conditions, etc., and pay sufficient attention to work implementation and selection of equipment.

1.2.2 Inspection before work



Warning

- 1) Operation with safety device and safety cover removed is dangerous, please check the normal condition.
- 2) It is very dangerous to operate without the safety devices and related parts that are standard equipment as well as safety covers. To prevent accidents, be sure to use these parts with them attached. If there is any abnormality, repair it and check the normal condition before operating the work.
- 3) When the work clutch (Blade clutch, etc.) is in the "disengaged" position, check that the V-belt is securely stopped. If it is moving even a little, stop the engine, adjust the belt retainer, and adjust the wire.
- 4) The falling off of the Blade is dangerous. Please tighten the set bolt and nut of the Blade securely. Also, please replace the old one with a new one.
- 5) If there is an opening / closing cover for Blade replacement, it is dangerous to use while keeping it open. Be sure to use it in a closed state.
- 6) Always check the effectiveness of the parking brake. Incorrect brake adjustment may cause a serious accident. Please check with one or more of the following.
 - (1) When the Driving clutch lever is in the "off" position (the sub-change shift lever is in the "N" position), the parking brake is applied and when push it with two adults do not move.
 - (2) Tires lock up during sudden braking while driving.
 - (3) The parking brake is working on the 2m bridge which hooked it on the bed of a light truck.
- 7) Before starting work, be sure to remove the cooling air intake of the engine, the clogging near the cylinder, especially the high temperature around the exhaust pipe and the debris accumulated on the machine. It may cause engine burn-in or fire.
Also, clean is not only the outside but also the inside of the air cleaner and the inside of the HST fan cover (applicable product) at the same time.

1.2.3 No fires • Fuel supply



1) Please do not bring the fire close while working or refueling

Do not use cigarettes, bonfires etc., naked flames etc. absolutely near the machine.

2) After stopping the engine, please refuel after the muffler temperature drops sufficiently.

3) For refueling, if there is a fuel level upper limit mark, please do not exceed the mark.

Please remove the Fuel when it is too much to be below the mark.

Also, be sure to wipe spilled fuel.

4) Please do not refueling when the body is charged with static electricity.

There is a possibility of ignition due to vaporize gasoline, there is a big risk of burns and fire.

1.3 During work

1.3.1 Precautions of while working

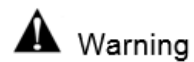

1) Please try to driving safely, and do not start suddenly, stop suddenly and do not turn abruptly.

2) Please do not work in an unreasonable posture and take a rest within 1-2 hours according to your physical condition.

3) To prevent people (especially children) and pets entering the working area (within a radius of 10 m), set a standing tag or guard rope to indicate that the Grass cutting work is processing in inside and do not approach within a radius of 10 m.

When a person or pet approaches, stop work immediately and stop the engine.

4) Do not put flammable or dangerous materials around while driving. Also, the exhaust muffler becomes hot. There is a risk of burns if your hands are touched when operating the machine or immediately after finishing work.

5) For work on the slope, please use the slope of **20 ° or less**. Please do it in the lateral direction (contour direction) rather than the vertical direction. If the machine is used at an inclination of 20 ° or more, the machine may overturn and become the underlay of the machine.

6) Please take precaution to prevent slippage well. But although please do not work in slippery places.

1.3.2 Operational precautions

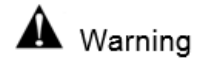

Warning

- 1) Be sure to sit on the seat, move the cutting height adjustment lever to the "move" position, and depress (or lock) the parking brake pedal to start.
- 2) Beware when turning and other operations on the slope. There is a fear of breaking the balance and falling and injuring.
- 3) On the slope, please do not perform unnecessary operation of shift lever and clutch lever for safety. There is a risk of slipping, falling.
- 4) When backward moving, please be careful that people (especially children) · animals · obstacles are not caught in the machine and fall over due to a step, cliff.
- 5) When working around trees and walls, be careful not to get caught by the body, hands, legs, pillars, tree branches, or wires.
- 6) When changing the cutting work direction, please check the safety in the front and back direction.
- 7) Operate the work (Blade / Rotary) clutch after confirming that there are no people (including Children) or animals, and paying sufficient attention to safety.
- 8) Before doing the Clutch operation (Knife · Rotary), Please confirm that there is no person (Inc. Children) and animals.

1.3.3 Inspection while working · stop · cleaning

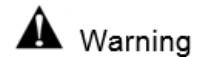

Warning

Carefully remove the debris where the intake of cooling air, the clogging near the cylinder and especially the debris accumulated around the exhaust pipe that becomes hot. It may cause an engine seizure or fire.

Also, clean the inside as well as the outside. Also, clean the inside of the air cleaner and the dust accumulated on the HST fan cover at the same time.



Caution

- 1) When checking on during work, please be sure to stop the engine and use gloves to protect your hands, after each part has cooled down.
- 2) when leaving the machine be sure to turn off the Engine. Also, please make sure to park at a stable flat area.
- 3) When stopping the engine, please do the following procedure (for the applicable product).
 - ① Apply brakes. ② Remove the key. ③ Close the fuel cock
- 4) Since abnormal sounds, smells, heat generation during driving may cause fire, stop the engine immediately and check and repair it.
- 5) If a foreign object collides (bites in) during work, immediately stop the work (Mowing, Tilling, etc.) and stop the engine. Be sure to inspect the Blade, Blade stay, Tilling blade and covers for cracks or bends, and correct or replace as necessary.
- 6) If you feel any abnormality other during the work, be sure to stop the engine before checking.

1.4 Notes on loading and unloading



Danger

- 1) Be sure to stop the engine and bring the fuel cock to the "closed" state when transporting this machine. Due to fuel leakage, spilled fuel may catch fire.
- 2) Do not tilt the machine beyond necessity. Fuel leakage may occur.

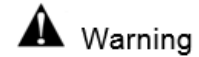

Warning

- 1) Please use a suitable car according with the Machine for transportation.
(Loading weight, size of loading platform, presence or absence of interference)
- 2) Select a flat and safe place for transportation vehicles, stop the engine so that it does not move when mounted, pull the side brake, and stop the wheel.
- 3) Adjust the height until the knife / claw does not contact the bridge. Also, please do the following for the applicable model. ① Work clutch is in "OFF" position. ② Position the diff-lock to the "ON" position.
- 4) Please make sure to apply a sturdy bridge that meets the standard with a loose slope (15 degrees or less), lower the engine rotation, loading "forward", slowly at low speed in "backward" when unloading.
<At that time, the operation to change speed and direction is dangerous, please do not do. >
- 5) Beware , When the machine crosses the boundary between the bridge and the truck bed, the position of the center of gravity suddenly changed.
- 6) When transporting, please be sure to secure with a tough rope etc. Please also keep safe driving.

1.5 Inspection / maintenance

◎ **Periodic inspection is essential for maintaining quality and performance.**

<Please note , we cannot assume about the responsibility for accidents and breakdown due to neglect of periodic inspection.>



Warning

Failure to observe the contents stated below may cause burns, injury or machine damage.

- 1) Perform daily inspections before and after used, and maintenance, periodically inspect and maintain to ensure that the products are kept safe and comfortable at all times.
- 2) For Inspection, adjustment and maintenance, stop the engine, wear heavy duty gloves after the overheated part of the muffler part and other mission case has completely cooled down, then use the correct tool correctly.
- 3) Inspection, adjustment, maintenance should be carried out in a place where the ground is flat and hard, wide and bright, always keeping in mind the balance of the machine, please be careful not to fall over.
- 4) When checking by lifting the machine, be sure to prevent falling.

- 5) When replacing or installing / removing a knife / blade or tire / crawler, please make sure that it is securely tightened in the specified location or firmly tightened.
- 6) When replacing the knife / blade or tire / crawler with a new one, please replace the mounting bolts together with a new one of the manufacturer genuine products for safety.
- 7) It is dangerous to damage the safety cover of the belt and knife part and the cover for preventing scattering. Please do not leave the part where you feel abnormality during work, always interrupt the work, inspect again, please check again after work, please make necessary repair
- 8) Be sure to install the removed covers correctly in their original positions.
- 9) Please do not set the attachments or modification which are not specified.
- 10) When the fuel pipe becomes old, it becomes a cause of fuel leakage and it is dangerous. Replace it with a new one along with the tightening band each 3 year or when it gets injured.

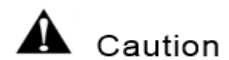

Failure to observe the following precautions may damage the machine.

- 1) When washing the machine, please do not spray water on the engine part (electrical parts, near the air cleaner, fuel cap etc.) and warning labels pasting place.
- 2) Check and adjust the clutches, throttle, gear change etc thoroughly.
- 3) For in case of covering please wait for "about 5 minutes or more" after stopping the engine to prevent burns and fire, after checking the cooling condition of muffler and engine body fully.

1.6 Storage



- 1) For safety, please be sure to close the fuel cock.
- 2) When storing this machine for a long time, please keep it indoors.
- 3) Please remove dust and foreign matter attached to the main body and working part.

1.7 Warning display mark



- 1) Warning indication marks are carefully selected as important items among important hazards within this item, and are affixed to the main unit.
Please fully understand and be sure to observe it.

Location of warning Label

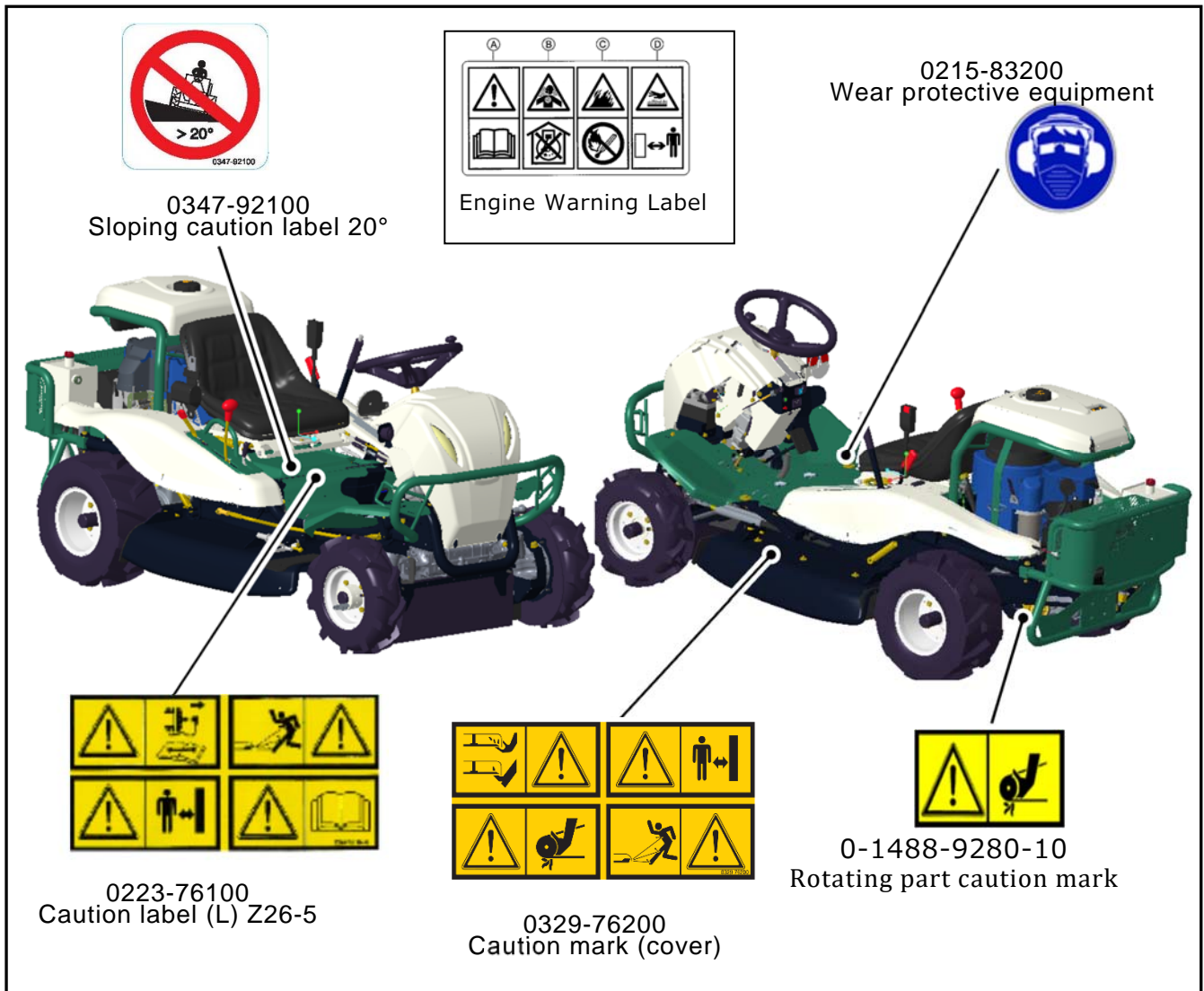

Meaning of caution label

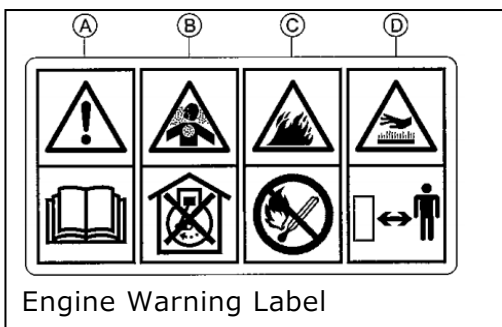

A. The Owner's manual contains important information on safe operation. Read it before operating engine.
B. Exhaust gas contains carbon monoxide, an odorless and deadly poison. Do not run Engine in an enclosed area.
C. Gasoline is extremely flammable and explosive. No open flames or other source of ignition.
D. Engines can become extremely hot during normal operation. Keep away from hot parts of the engine.



Meaning of caution label



Beware of cutting Blade



Be careful of rotating objects inside the cover.



Stand clear of the machine



Beware of thrown object



Read Owner's manual.



Before doing maintenance remove the spark plug.

2. Names and Functions of each part

2.1 Name of each part

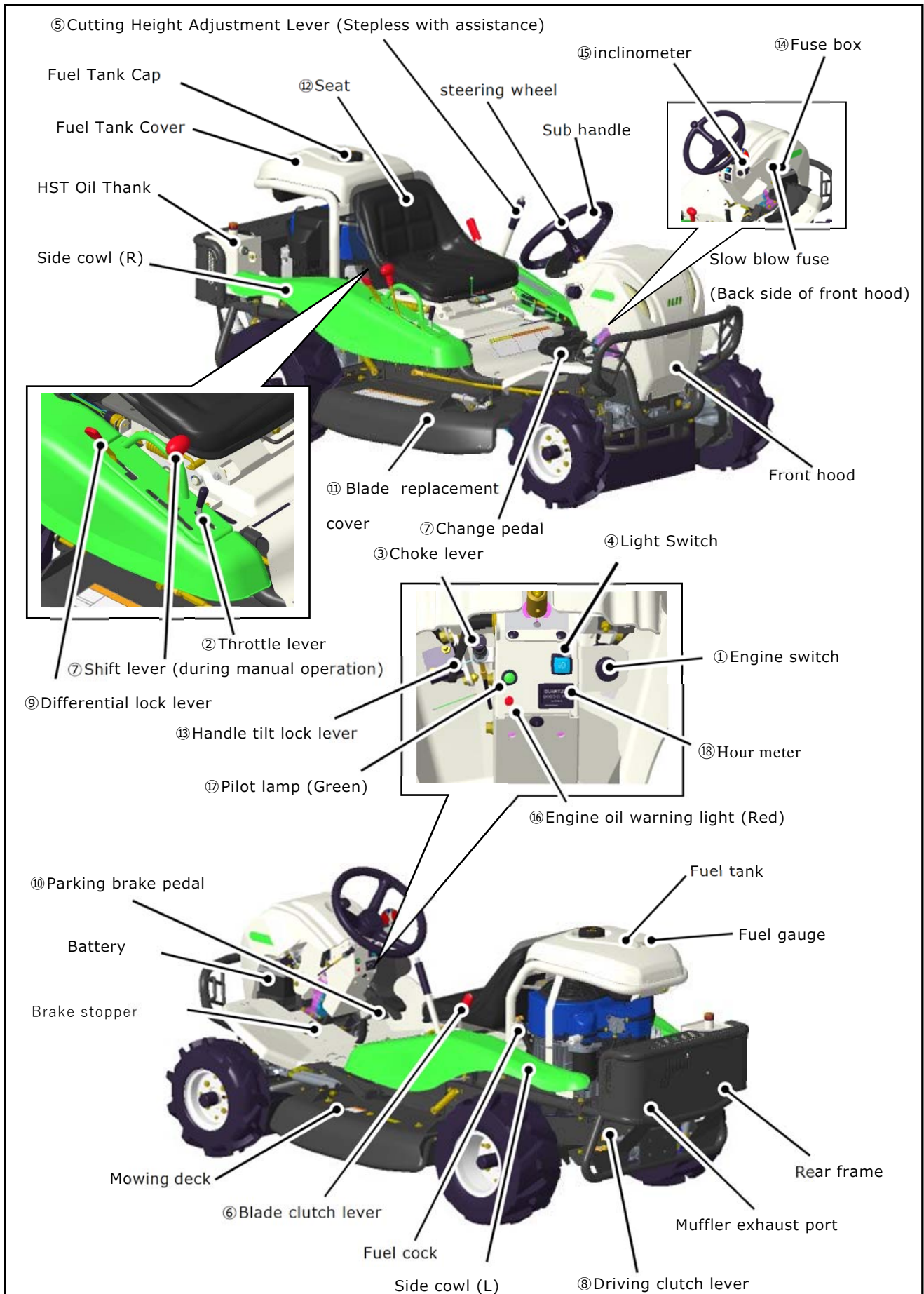

2.2 Function of each part



① Engine switch

Insert the key and operate "START", "RUN", and "Stop" of the engine.

② Throttle Lever

Adjust the engine speed from "Low speed" to "High speed".

③ Choke lever

Used to start the engine in cold weather. If you pull it "closed"  position, "Open" if returned  position. No action required if engine is warm..

④ Light Switch

Press to turn on (ON, light lit), press again to turn off (light off). When the switch is "ON", the switch lights blue.

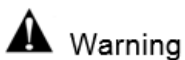

Warning

This light is for Moving. Never use it for work. There is a risk of collision, falling, etc. because the surrounding situation cannot be grasped. Please drive at low speed when the light is on.

⑤ Cutting Height Adjustment Lever (Stepless with assistance)

This product can be set to any cutting height between 10 and 80 mm. Press the cutting height lock button at the tip of the cutting height adjustment lever with your thumb, adjust it to the desired height and release the lock button to fix the cutting height at that position (see the figure below). As a guide for cutting height during adjustment, align the lever position with the scale label on the right side of the lever. The engine will not start except in the "move" position (maximum pulled up position). The Blade cut height is different when the Blade is rotating and when it is stopped. The scale is the value when the Blade is rotating in the test field. Please refer to it as the cutting height during actual mowing work (It depends on the working environment.)



Caution

Adjust the cutting height by pushing the lock button firmly to the end. If you stop the operation halfway (press halfway), it may cause a malfunction. For safety, be sure to set the cutting height adjustment lever to the "move" position when entering, leaving, or moving backward in the work field.

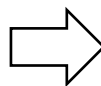

⑥Blade clutch lever

Turns the Blade rotation "ON (rotation)" and "OFF (stop)". The Blade clutch lever cannot be operated when the cutting height adjustment lever is in the "move" position.

⑦Change pedal · Speed change Shift lever

Used for running / stopping the product, running direction and speed adjustment. Push the change pedal forward from the neutral position to move forward, and toward the heel to move backward. The speed can be adjusted steplessly depending on the angle of depression. If you do not step on, it will automatically return to neutral



Reference ;

- 1) If you want to make it harder to return the Speed change shift lever while driving, tighten the change brake adjustment screw (see the upper right photo) to the right (in the direction of the arrow) to brake and make it difficult to return. Please note that it will be need heavy operation.
- 2) The Speed change pedal works together only when the Speed change shift lever is tilted to the right and placed in the guide groove. Otherwise, the change pedal alone will move.

⑧Driving clutch lever

Normally, use it in the "ON" position. (On the lower left rear part of the machine , there is a running clutch as shown below.) If the engine cannot be started, such as when the battery is exhausted or indoors, it will be easier to move by pushing the unit by setting it to the "OFF" position. <4.2.4 Refer to How to move when you cannot drive>



⑨ Differential lock lever

Normally, use it in the "off" position. When working on a gentle slope or on a soft ground, or when one side of the rear wheel is slippery and it is difficult to go straight, or when loading / unloading to / from a truck, set the diff lock lever to the "ON" position to set both sides of the rear wheel tires are directly connected, which improves straightness.

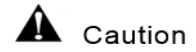

Caution

If you use a flat ground, the turning radius will be large, tires will be worn out, and it may cause mission damage.

⑩ Parking brake pedal

In case of an emergency, if you fully depress the pedal, the brake will be applied, then machine will be stopped, and the shift lever will be returned to the "neutral" position. For normal stop operation, always use the change pedal or shift lever to stop. Keeping the pedal depressed and lock with the brake stopper, it will be a parking brake. The lock is released when you step further. The engine cannot start unless the pedal is depressed (locked).

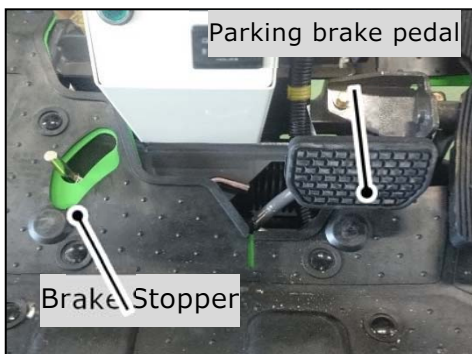

⑪ Blade replacement cover

When inspecting or replacing the Blade, you can fix it with the cover open.

〈5.4.1 Refer to How to open and close the Blade replacement cover.〉



Warning

Be sure to close the Blade replacement cover while working. Mowing work with the cover open is extremely dangerous as it causes increased scattering of foreign matter such as stones. Make sure the cover is closed and locked when except Blade inspected or replaced.

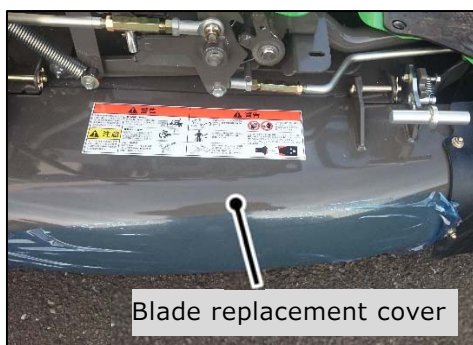

⑫ Seat(Seat slide and Seat suspension functions Equipped.)

Adjust the seat slide front and back by raising the slider lever in front of Seat. The suspension can be adjustable the strength of the spring force according to the weight of the worker using the "suspension adjustment bolt" on the front of the seat in the left photo. Turning it clockwise will make it stronger, and turning it counterclockwise will make it weaker. After starting the engine, the engine will stop for safety if you leave the seat when the cutting height adjustment lever is not in the "move" position and the parking brake pedal is not in the "lock" position (the pilot light will not go out and the engine switch is keep to (RUN) state).

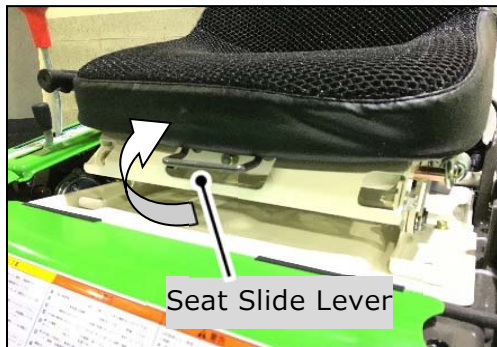

Caution

If the engine stops, immediately turn off the engine switch. Or Re start the engine.
If the engine is stopping for a while, the battery will run down.

〈4.1 Refer to How to start and stop the engine〉

⑬ Handle tilt lock lever

The angle of the handle position can be adjusted according to the physique of the worker. Loosening the lock lever and tighten it at any position to lock it. The lever will be free when pulled up. After deciding the steering wheel angle, you can fix it at the desired position.

Caution

Do not operate the handle tilt while driving as it is dangerous.

⑭ Fuse box

Protects the harness and electrical components in case of overcurrent. There are 10A (accessory) and 20A (charge) fuses, and a separate 20A fuse is included as a spare. If the fuse blows, remove the cause and replace it with a spare fuse. also, use the spare fuse only for emergencies and immediately replace it with a regular A (ampere) fuse.

⑮ inclinometer

When working on a sloping ground, the pointer on a simple inclinometer indicates a reference angle for the location. If you want to measure the angle more accurately, use a handheld type angle meter.

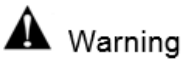

It is dangerous to work on a sloping ground over 20 °, so work under the 20 °.

⑩ Engine oil warning light (Red)

Illuminates when the engine switch is in the "Run "position and the engine is stopped, but remains off when the engine is running. If it is lighting when the engine is running, the engine oil is low. Stop the engine immediately, check the amount of oil, and add an appropriate amount. 〈5.1.2 Refer to engine oil inspection and replacement〉

⑪ Pilot lamp (Green)

Illuminates when the engine switch is in the "RUN" position.

⑫ Hour meter

The approximate usage time is measured and displayed. Use it as a guide for maintenance time.

2.3 Direction of definition

The front, back, left, and right of this machine are expressed as seen from the operator sitting on the seat as shown below. "Forward" and "Reverse" in the text are also expressed as seen from the operator.

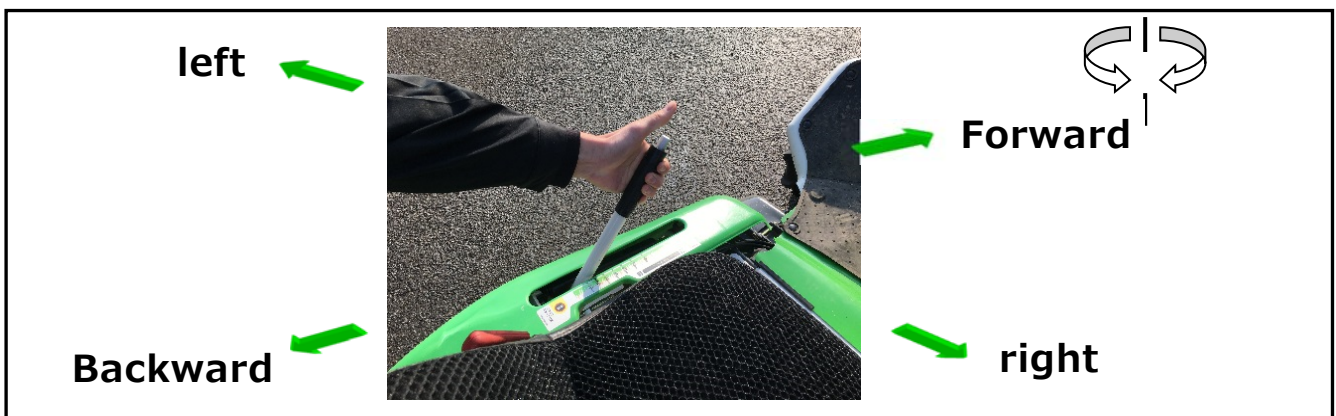

3. Inspection before work

- Before starting work, check "1.2 Before Starting Work" and check the following "Before starting work checklist" and Be sure to perform the pre-operation inspection according to "7.1 Periodic inspection table".

※If you have any questions or problems, please be sure to contact the dealer where you purchased the product.

Pre-operation checklist (summary from regular checklist)		
	Item	Inspection contents
Engine	① Engine oil	Check "oil amount and dirt" <Refer to 3.1>
	② Air cleaner	Check for "dirt" and clean <5.2.1>
Machine Body	① Blade (Knives)	<Refer to 5. Inspection and maintenance>
	② Brake (Applicable product)	"1" bolts and nuts are loosened or dropped
	③ Tire (crawler)	"2" Deformation, wear, interference
	④ Levers	"3" Smooth movement or Sticking
	⑤ Covers	"4" Remove foreign matter such as garbage, grass and straw
	⑥ HST oil (Applicable products)	Check "oil amount and dirt"



- 1) Be sure to stop the engine before Checking, Refueling, Adjusting or Servicing.
- 2) When starting the Engine and Checking the operation of the Driving clutch lever etc., Check the safety of each Lever position and the surrounding of machine.
- 3) Make sure you understand the warning markings on the Machine.

3.1 Check engine oil

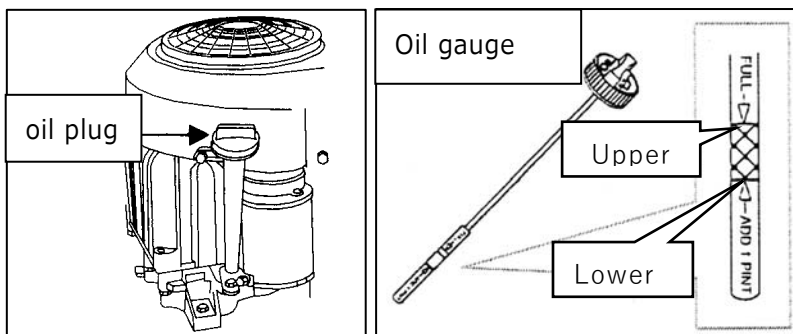

- ① Level the machine and remove the oil gauge.
- ② The tip of the Oil plug is an oil gauge. Wipe the gauge part with a cloth. Place the engine horizontally. Briggs Engine : screw in oil plug. Kawasaki Engine only

insert oil plug without screwing. Check the amount of oil. If there is no oil mark between the upper and lower scale lines, add engine oil so that the oil reaches the upper scale line.



Caution

- 1) If you want to check the engine oil after the engine is running, wait for "about 5 minutes or more" after stopping the engine, and check the cooling condition of the muffler and the engine itself.
- 2) Be sure to check the engine oil level before starting, as excessive or insufficient engine oil may cause a malfunction.
- 3) The engine oil is of high quality above SF / SG / SH / SJ grade, use "10W-30" oil, and do not use commercially oil additives.
- 4) After replenishing, securely tighten the oil gauge. If tightened loosely, engine oil may leak out.

「Recommended oil」

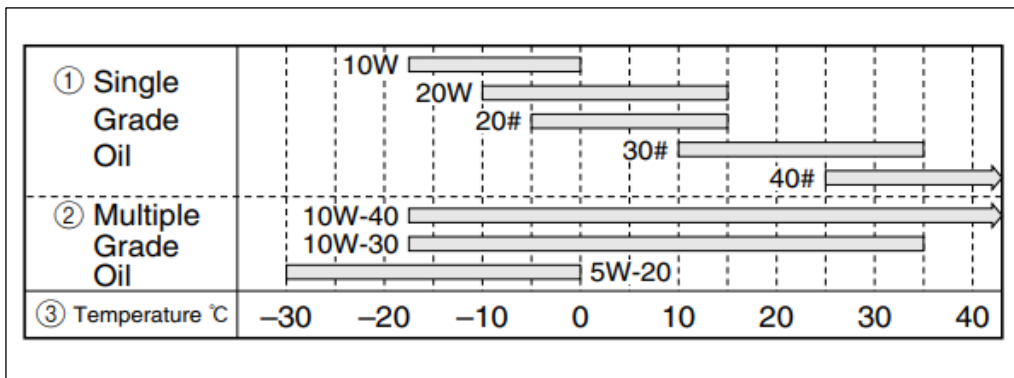

3.2 Fuel inspection and refueling



- ① Set the horizontal, remove the filler cap and check the amount of fuel from the filler.
- ② Refuel as soon as the fuel gauge approaches the "E" position. (Fuel used: Unleaded regular gasoline)

- ③ Do not put fuel above the middle of the filter.
It may cause fuel leakage on uneven roads and slopes. The leaked fuel will be discharged to the front of the tank, but wipe out the spilled fuel.

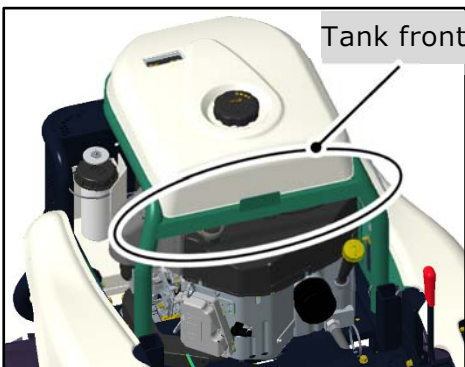

- ④ After refueling, securely tighten the fuel filler cap.
※ Fuel gauge is a guide. Keep the fuel up to the middle of the filter and be careful not to overfill it. If it spills, wipe it clean. Especially when using on sloping ground, use below the bottom of the filter. Risk of fuel leakage due to tilt.



Danger

- 1) **Fire is strictly prohibited during work and refueling.** Risk of ignition and burns. Never use a cigarette, bonfire, or open flame near the machine.
- 2) Refueling, after the engine has stopped and the muffler temperature has dropped sufficiently.
- 3) If there is an oil level upper limit mark, refuel below the mark. If you put too much, remove it until it is below the mark. Also, be sure to wipe off any spilled fuel.
- 4) 4) Do not refuel this when your body is charged with static electricity. Vaporized gasoline may cause a fire, which may result in burns or a fire.



Warning

Refuel in a flat, stable, and well-ventilated place.

Risk of ignition and burns if gasoline spills.



Caution

- 1) When refueling, make sure that no foreign matter such as dust, grass, rain or snow gets into the fuel tank. May cause engine malfunction.
- 2) Only use unleaded regular gasoline. It may damage the engine.
- 3) Gasoline will deteriorate naturally. If you do not use it for more than a month, replace it with new gasoline. Also, do not use gasoline stored for a long time in a plastic tank. May cause trouble.

4. Operation and work



Warning

※Be sure to read 「"1. Precautions"」 before driving.

Especially read and understand "1.1 Working Conditions", "1.2 Before Working" and "1.3 Working". Start to operation and work.

4.1 Starting and stopping the engine

4.1.1 How to start the engine

Reference ;

- 1) Be sure to sit on the seat and start the Engine.
- 2) Be sure to depress (lock) the parking brake pedal before starting the Engine . If the pedal is not depressed, the safety switch will work and the Engine will not start.
- 3) Be sure to set the cutting height adjustment lever to the "move" position. The Engine will not start if the safety switch is activated except in the "move" position.

For your safety, please follow the above three rules when starting the engine.

Start the engine after carefully checking each operation method.



Danger

When starting the engine, carefully check the position of each lever and the surrounding safety. Do not start or warm up the engine in a closed room. Starting the engine in a closed room would be polluted the air with harmful exhaust gases and cause gas poisoning. It is equipped with a gasoline engine, working with cigarettes and bonfires near the machine can be dangerous. Please do not this.

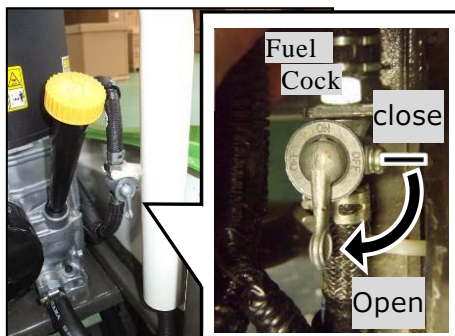

- ① Move the fuel cock to the "open" position.
- ② Sit on the seat.

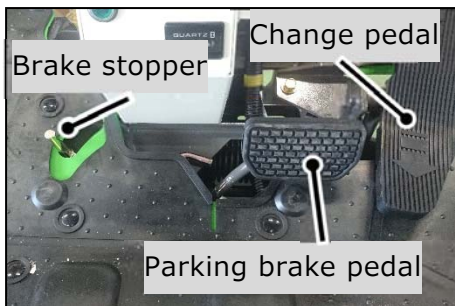

③ Depress the parking brake pedal and apply the brake stopper. If the change pedal or shift lever is not in the neutral "N" position, return it to the neutral "N" position.

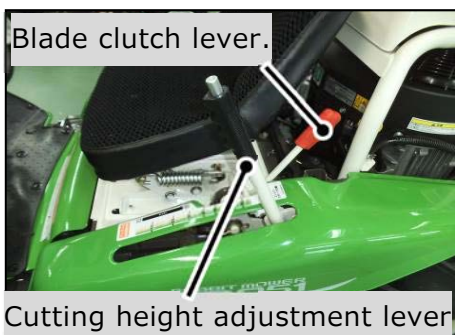

④ Set the knife clutch lever to the "off" position and the cutting height adjustment lever to the "move" position.

Reference ;

The Blade clutch lever is linked to the cutting height adjustment lever. Move the cutting height adjustment lever to the "move" position and the Blade clutch lever will also return to the "off" position.



⑤ After confirming that the shift lever is in the neutral "N" position, pull the Choke lever. (The state where the lever is pulled is the "closed" position, and the state where the lever is pushed is the "open" position.) (This is not necessary if the engine is warmed-up.)



⑥ Move the Throttle lever to the middle position between High speed and Low speed.

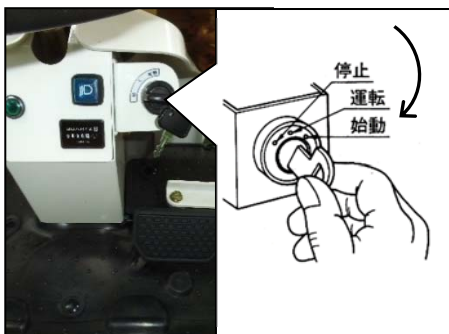

- ⑦ Insert the key into the engine switch and continue turning the key from the "run" position to the "start" position to start the engine.
- ⑧ Release the keys as soon as the engine starts. Automatically returns to the "drive" position.
- ⑨ After starting the engine, push the choke lever back to the "open" position and return the throttle lever to the "low speed" position and warm up for a while .

**Caution**

The starter motor consumes a large electric current, so please avoid continuous use for more than 5 seconds. If it does not start within 5 seconds, return the engine switch to the "stop" position, pause for 10 seconds, or more, and then repeat the same operation. Do not put the engine switch in the "start" position while the engine is running. It may cause a failure of the starter motor. If the engine is warm enough, start the throttle lever in the "medium speed" position. (It does not necessarily have to be in the choke ``closed `` position.)

Reference ;

Warming up the engine, it spreads oil throughout the engine and extends the life of the engine.

**Warning**

For your safety, be sure to "lock" (park) the parking brake pedal with the brake stopper during warm-up operation.

4.1.2 How to stop the engine

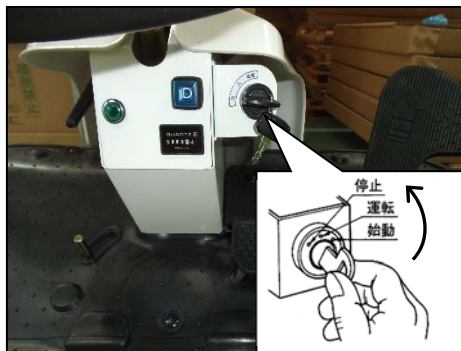

- ① Pull the throttle lever toward you to move to the low speed position.
- ② Stop the engine with the key in the "stop" position.
- ③ Remove the key from the engine switch.
- ③ Finally, move the fuel cock to the "OFF" position.

4.2 Driving, Speed change, Turning and Stopping

warning

Do not use by unskilled people (people other than the owner) in safe work and operation methods.

When you drive for the first time, check the safety of your surroundings and practice at a low speed on a flat surface without obstacles until you are familiar with the operation and features of the product. If you drive at a high speed suddenly, it may be confusing to operate when it is emergency case.

4.2.1 How to drive



- ① Start the engine.

〈4.1.1 Refer to How to start the engine〉

- ② Move the throttle lever to the "high speed" side to increase the engine speed.



- ③ Depress the parking brake pedal deeply to release the brake stopper. Never operate the change pedal (shift lever) while the parking brake pedal is "locked". This will force the braked wheels to be driven, resulting in overloading of the brakes and the transmission, which can cause damage.

- ④ Slowly tilt (depress) the speed change lever (change pedal) forward to move the machine forward.

Reference ;

The Driving speed changes steplessly depending on the angle at which the speed change lever (change pedal) is tilted. Release the change pedal to return to neutral N. For the safety Start slowly .

4.2.2 How to stop (park)

⚠ Caution

When you depress the parking brake pedal, driving stops and the gear shift lever and change pedal return to the neutral "N" position all at once, and then stop. However, please make a habit of using the gear shift lever or change pedal to stop Driving normally. Especially when the parking brake pedal is depressed or the foot is released from the change pedal at high speeds, a sudden stop may cause a physical shock to the operator and overload the vehicle body.



- ① Stop the Driving.
- ② Set the throttle lever to the "low speed" side to slow down the engine rpm.
- ③ Stop the engine.
(4.1.2 Refer to How to stop the engine)
- ④ Depress the parking brake pedal and "lock" with the brake stopper to park.

⚠ Caution

Park the machine on a flat surface with no obstructions in the surroundings, and remove the key switch to prevent theft.

Reference ;

Be sure to use the engine switch to stop the engine.

If you lock the parking brake and move the cutting height adjustment lever to the "move" position, the engine will not stop even if you stand up from the seat, but if you stand up from any other position, the engine will stop for safety. (The pilot lamp does not go off and the engine switch is in the "RUN" state. In this case, leaving it as it is may cause the battery to run down). Be sure to return the parking brake and the cutting height adjustment lever to the moving position, and the key to the "OFF" position.

After starting the engine, the engine will not stop if you are sitting on the seat regardless of the positions of the parking brake pedal and the cutting height adjustment lever.

The drive system of this machine is hydraulically controlled on-demand four-wheel drive.

The hydraulic control automatically switches between the two-wheel drive state and the four-wheel drive state, so there is no need for the operator to perform the switching operation.

The front wheels are not driven when the vehicle is running with a light load (flat land, etc.). (Two-wheel drive state).

The front wheels are driven when driving under heavy load (hill, soft ground, etc.). (4 wheel drive condition).

4.2.3 How to operate the differential lock lever

⚠ Caution

Use the diff-lock lever only when loading and unloading, working on gentle slopes, or when it is difficult to go straight due to one of the rear wheels spinning in a soft place on the ground, and do not use it elsewhere. If the diff-lock is used on a flat surface, not only will the inner tire be dragged during turning, the turning radius will increase, but also tire parts will be overloaded and other parts of the body (especially the inside of the mission) will be overloaded, causing malfunction.

Hook the diff-lock lever into the notch only in the above cases, and always return the diff-lock lever to the "off" position in all other cases.

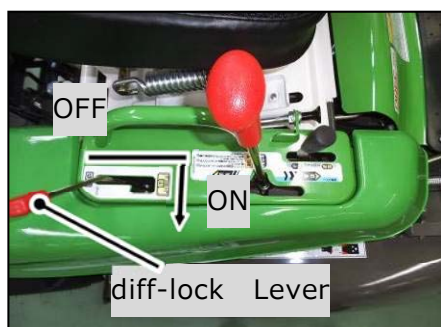

- ① Normally leave it in the "off" position. Only if you need a diff-lock on muddy or steep slopes, put the lever in the "on" position, make a notch, and "lock".
- ② Be sure to return the diff-lock lever to the "OFF" position after escaping from mud.

4.2.4 How to move when it cannot run



On a flat ground, setting the Driving clutch to the "OFF" position makes it easier to push the Machine without starting the engine.

This is used for engine troubles, etc.

⚠ warning

- 1) Always put the Driving clutch lever in the "ON" position except when pushing it without Engine power.
- 2) For safety, be sure to press two people (operating and pushing).
- 3) Because it is a hydraulic 4WD, the front wheels are not going to neutral. (Only the rear wheels are neutral.)
- 4) Do not move the Driving clutch lever to the "OFF" position on slopes.
It is very dangerous because it may cause slipping.

4.3 Loading and unloading , Transportation.



- 1) Always stop the engine and keep the fuel cock in the "closed" state when transporting the machine. Fuel leaks can cause spilled fuel to catch fire.
- 2) Also, do not tilt the Machine more than necessary. Fuel may leak out..



- 1) Be sure to use the bridge. Loading and unloading this product (using a UNIC vehicle, etc.) not only causes problems such as frame deformation, but it is also dangerous because it may fall. Please do not do it.
- 2) Do not stop in the middle of the bridge. Especially in the case of a rear load, the front wheels may rise when restarting, which is dangerous. Please load and unload all at once at low speed.
- 3) Please use a truck without a ceiling (hood) for the truck. When loading and unloading, there is a risk of collision with workers depending on the height of the ceiling.
- 4) Choose a flat and stable location and do not operate it on public roads.
- 5) Use a truck that can be fit for the total weight of this product and the total weight of the driver.
- 6) To prevent accidents when working with multiple people, setting the signal with the truck driver.
- 7) Loading and unloading at night is dangerous. If it is unavoidable, select a place where sufficient lighting can be obtained before performing the work. If it is difficult for the operator to check the position between the bridge and the tires, there is a risk of falling.
- 8) Stop the engine on the truck, engage the parking brakes, and block the tires.
- 9) Be sure to set the cutting height adjustment lever to the "move" position. The blade may touch the bridge and turn over it.
- 10) The diff-lock lever should be "ON" position on the bridge.
- 11) Be sure to hang the bridge hooks so that there are no steps on the truck bed.
- 12) Make sure that the left and right tires of this machine are in the center of the bridge.
- 13) The engine should be stopped on the Truck, the fuel cock should be "closed" and the key removed. Use a rope that is strong enough to securely fasten this machine and securely fasten it on the Truck.

4.3.1 loading and unloading



• Cutting height adjustment lever is in "move" position



Diff lock lever is in the "on" position

- ① When loading, move forward, and when unloading, move backward.
- ② Use the standard the bridge .
- ③ Put the differential lock lever in the "ON" position, the cutting height adjustment lever in the "Move" position, and do not put it in any other position.
- ④ Move the throttle lever at the medium speed position.

Reference ;

Bridge Standard

Use a bridge that meets the standard and has sufficient strength.

- Length…Length is more than 3.5 times the height of the truck bed.
- Width…Width is fits the wheel width of this machine.
- Strength…Sufficient to withstand the weight of this machine and the total

4.4 How to do the good work

warning

- 1) Continuing to work with grass clippings around the engine may cause a fire or engine burning. Especially, frequently remove the grass debris accumulated around the exhaust pipe that becomes hot. Also, regularly clean the inside of the engine cover as well as the outside.
- 2) The cut grass is spit out from the Blade replacement cover on the right side of the product, but foreign matter such as stone blocks, wire, and empty cans will scatter from the entire circumference of the cutting section, which may cause damage to the surrounding area. In the vicinity of buildings or in fields with many foreign substances, remove these before work and do high mowing or keep them distane enough to prevent people (especially children) and vehicles from entering the work place.

- 3) If mud or dust adheres to the cooling part, the oil temperature will rise. Perform regular maintenance.
- 4) To prevent a fall or collision, do not work in the direction of buildings, rivers or cliffs, or people.
- 5) It is especially dangerous to stand on the upper side (mountain side) of the product when working on sloping ground. Sliding your feet can cause serious injury if you are caught in a rotating Blade.
- 6) Always stop the engine and make sure the Blade has stopped rotating before removing grass, wire or other foreign matter entwined with the Blade.
- 7) Do not start work until you have confirmed that the part where the defect was confirmed in the previous work has been reliably repaired.
- 8) In order to perform work safely, refer to <5.4 Knife inspection / replacement / installation> and perform a pre-work inspection of the Blade and Blade stay.
- 9) Be sure to use the attached special tool for attaching and detaching the Blade. If it is not used, sufficient tightening torque cannot be obtained, and the Blade may scatter due to the Setting bolt falling off.

 **Caution**

- 1) For work clothes, wear long-sleeved jacket and long pants with a narrow hem, and be sure to wear non-slip boots, a hat or helmet, dust-proof glasses, and protective gloves.
- 2) Remove foreign matter such as stumps, stones, wires, empty cans, and sticks before work.
- 3) Be sure to use a bridge when riding over a step of about 70 mm or more. Passing over bumps at high speed may cause a fall accident or malfunction. Also, be sure to go over at a low speed. Overcoming at high speed is not only a cause of failure, but also a very dangerous act even with a step of 70 mm or less.
- 4) If the front wheel falls into a hole or groove, make sure to stop the engine without turning the handle unnecessarily, then lift the product to escape. Unduly operation of the handle may cause a malfunction.
- 5) A front wheel collision with a stump, curb, etc. while driving or working may cause a failure.
- 6) When working under a branch or when working on a slope, pay close attention to accidents such as being caught between branches and falling accidents.

Reference ;

- 1) When using this product for the first time, select a flat surface free of foreign matter such as stones, and slowly mow straight so that the cut marks overlap slightly.
- 2) Mowed grass is discharged to the rear from the right side of this product. Always keep the trees, pillars, fences, and other obstacles to the left side of this product. (When

4.4.1 How to do the mowing work.

flat ground (open space)

When mowing on flat ground (open space, etc.)

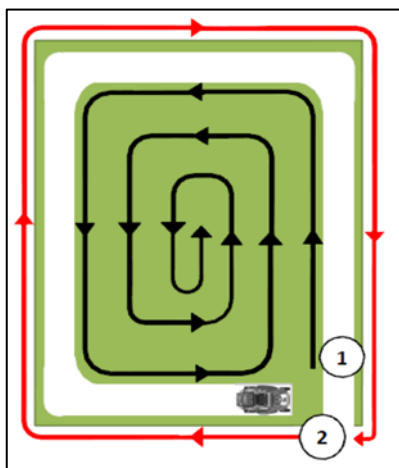

- ① In order to prevent scattering outside the field, leave the one row of grass outside and mow counterclockwise from outside to inside.
- ② When you have finished ① mowing, trim the left outer grass in a clockwise direction.

orchard

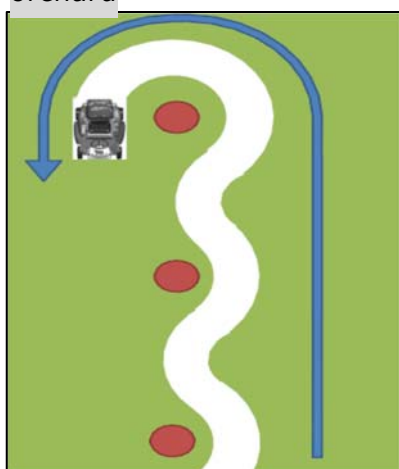

When mowing in an orchard

- ① To mitigate the damage to the trees by scattering, So mowing pass the right side of the trees as much as possible.

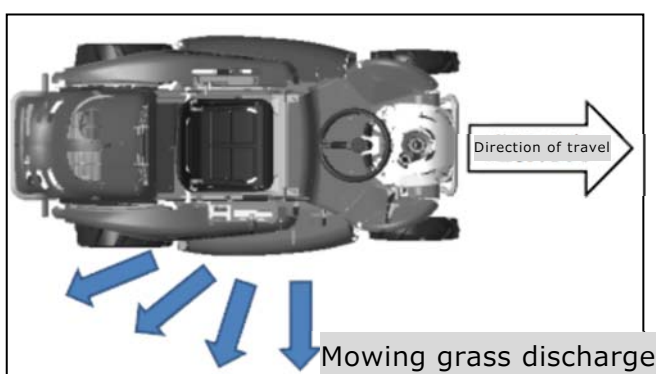



① Keep the knife replacement cover on the right side of this product closed when operating the mowing work.

② Start the engine.

〈4.1.1 Refer to How to start the engine〉

③ Turn the throttle lever to the high speed position and increase the engine speed.



④ First, adjust the cutting height adjustment lever to a cutting height position of about 70 mm. Adjust the lever position by referring to the scale display.

〈2.2 See Functions of each part ⑤ Cutting height adjusting lever (stepless with assist)〉



⑤ Then slowly tilt the Blade clutch lever to the "ON" position.

⑥ Fine-adjusting the cutting height adjustment lever again to the required cutting height.



⑦ Start the machine by referring to

<4.2.1 How to drive>.

⑧ To finish the work, reverse the above operation procedure.

⑨ Stop the engine.

〈4.1.2 Refer to How to stop the engine〉

Caution

- 1) Please be careful as the Blade rotates at high speed.
- 2) Operate the Blade clutch lever slowly.
- 3) If the Blade clutch lever is suddenly set to the "ON" position at the lowest cutting height position, the cutting belt will be damaged early due to a sudden overload.
- 4) When disengaging the Blade clutch, be sure to return the Blade clutch lever to the "disengaged" position, wait a few seconds (about 5 seconds), and then move up the cutting height adjustment lever to the "move" position. The Blade may be rotating, which may cause foreign objects such as stones to scatter. Please be careful.
- 5) Do not Pile grass or leaves on the engine. Accumulation of these combustible materials may cause fire or malfunction.
- 6) If the amount of grass is large and Engine stall frequently, reduce the working speed or increase the cutting height and cut in several times.

Reference ;

- 1) When using this product for the first time, select a flat surface free of foreign matter such as stones, and slowly mow straight so that the cut marks overlap slightly.
- 2) The mowed grass is discharged backward from the right side of the product. When cutting the side of an obstacle, be sure to place an obstacle such as a tree, pillar, or fence on the left side of the product.
- 3) When working on a gently sloping ground, be sure to mow so that the plug side of the engine (right side of the vehicle body) always faces upward (mountain side). In the opposite way, the engine oil may burn and emit white smoke.
- 4) For safety of this product, if the cutting height adjustment lever is returned to the "move" position, the Blade clutch lever will also be linked and it will return to the "off" position. However, if such a method is continued, a sudden impact on the cutting belt may occur, it's life will be significantly shortened. Please observe the operation method in 4.4.1 Mowing work except in an emergency.
- 5) The Blade clutch lever cannot be operated when the cutting height adjustment lever is in the "move" position.
- 6) For normal stop operation use the gearshift lever (change pedal). If you press the parking brake pedal in an emergency, the product will stop immediately. At this time, the shift lever (change pedal) automatically returns to the neutral "N" position.
- 7) When leaving the machine, be sure to stop the engine, remove the key, and keep it by the owner.

 **warning**

- 1) The Blade replacement cover can be fixed with the cover open, but mowing work with the cover open is very dangerous as foreign objects such as stones may scatter. Make sure that the cover is closed and that the lock is applied before doing the mowing work.
- 2) If you hit an obstacle during work, stop the engine immediately and repair if there is any abnormality. Resuming work without repairs may lead to an unexpected accident.
- 3) If the grass is wet or if it is raining, the machine may slip and it is dangerous. In addition, the mowing grass is clogged in the mowing deck, making the engine losing the power. If this happens, stop working and wait the grass to dry before restarting work. Working in the rain is very dangerous.
- 4) While the Blade is rotating, the Blade can be reached the inside of the covers on both the left and right sides, so please do not put grass etc. into the mowing deck with your hands or feet while working. <Refer to the figure below>

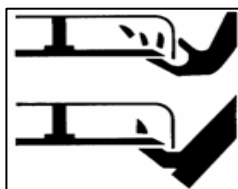

4.5 Adjusting the handle and seat position to suit your work and physique

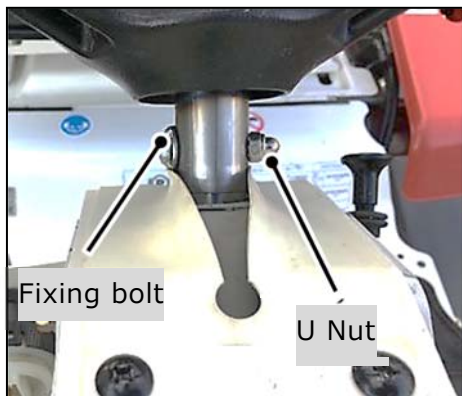

● The handle can be adjusted in three stages up and down also can be adjust front and rear (tilt). The seat can be slid forward and backward.

① Seat position

The seat position can be adjusted back and forth by pulling the lever and sliding according to the physique of the operator.

〈2.2 Functions of each part ⑫ See seat (with seat slide

and seat suspension function)〉

② Handle Up & Down

When adjusting the handle height, remove the fixing bolt, adjust the handle height, insert the fixing bolt, and then fix with the U nut.

③ Handle tilt

The front and rear (tilt) position of the handle can be adjusted forward and backward

〈2.2 Functions of each part ⑬ Handle Refer to tilt lock lever〉

4.6 How to use the moving light



The light switch is on the lower right side of the handle.

Press to "ON" and press again to "OFF" position.

When "ON", the switch lights blue.

This light is for Driving. Do not use it for work.

In an environment where it is difficult to grasp the surrounding situation, there is a danger of collisions, falls, falls, and death, which is dangerous. Also, please drive at a

particularly low speed when moving during twilight.

5. Inspection / maintenance / adjustment

5.1 Oil inspection / replacement / lubrication

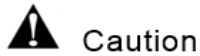

Caution

- 1) Refer to the hour meter display on this product's for guidelines on inspection, replacement, and lubrication of oil in each part.
- 2) Oil is filled in the machine at the time of shipment, but before using this machine for the first time, check again that the specified amount of oil is in the place before using.
- 3) Regular oil changes are necessary to ensure the machine is always in best condition.
- 4) When inspecting or replacing each part, be sure to place it on a flat and wide area to warm up the engine, stop it, and wait for the temperature of each part to drop (about 5 minutes).
 - …If you work immediately after stopping the engine…
 - ※Engine parts are extremely hot and there is a risk of burns.
 - ※Immediately after the engine is stopped, oil remains in the engine and various parts of the transmission, and the exact amount of oil is not indicated.
- 5) For your safety, remove the key and keep it with the owner until the work is finished.

5.1.1 Inspection and replacement of mission oil

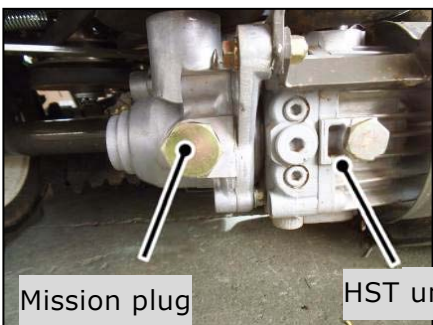

◎ Inspection / supply… strictly observe the amount of oil

- ① For inspection, please confirm by removing the Mission plug at the rear of the mission case. If the mission oil can be visually confirmed through the Mission plug port (up to the full lubrication port), the prescribed amount of mission oil is contained.

◎ Exchanging

- ② For Exchange , prepare an suitable container to receive the oil, remove the drain plug (oil drain plug) on the lower left side of the mission case , after **20 hours** used for the first time and **100 hours each** after that.

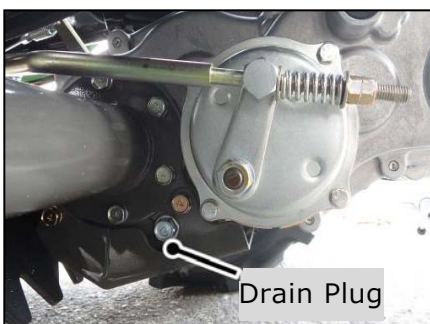

Guidelines for Exchange

First time: 20 hours, second time and thereafter: every 100 hours



- ① For lubrication, attach the drain plug (oil drain plug), remove the mission plug at the rear of the mission case, and add 1.0 liter of mission oil (# 90).

After lubrication, be sure to tighten the mission plug to prevent oil leakage. Be careful, not to overtighten the mission plug. After the gasket (O-ring) contacts the mounting surface, tighten it further by 3/4 turn.

5.1.2 Engine Oil check and change

◎ Inspection / supply

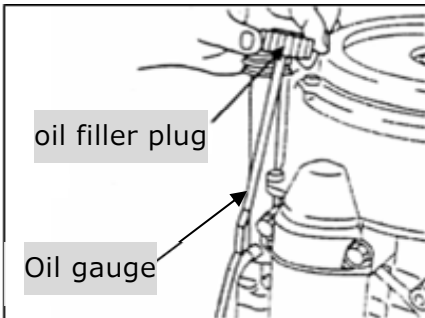

- ① Before starting work, check the quality and quantity of engine oil daily with the oil gauge attached to the oil filler plug. <See 3.1 Engine check>

- ② Always add engine oil to the upper limit of the level gauge.

<Reference, quality and quantity of oil used: 3.1 Check engine oil>

- ※ The first time is 5 hours, after that each 50 hours replace it, or every season, whichever comes first.

However, continuous work under severe working conditions or high temperature environment

It is recommended to replace the engine oil (about 25 hours) and the oil filter (about 50 hours) early before the above time is reached.



- ① Prepare a suitable container to receive the oil, loosen the oil filler plug, and then remove the drain plug (oil drain plug) on the left rear side of the engine using the tool M12 (Oil can be discharged smoothly by loosening the oil filler plug.)

- ② After draining the oil, firmly tighten the drain plug as before and remove the oil filler plug.

- ③ First, add 1 liter of oil and run at low speed for about 30 seconds. Stop the engine and wait for about 30 seconds, then slowly add oil to the "FULL" position on the level gauge.

<Reference: Engine oil amount: 6.1 Specification Sheet.>

- ④ Tighten the oil plug firmly so that the oil does not ooze after the engine oil has been added.



Caution

Excessive addition of engine oil may cause engine failure. If you put too much, pull it out and keep the proper amount.

5.1.3 Oil filter replacement

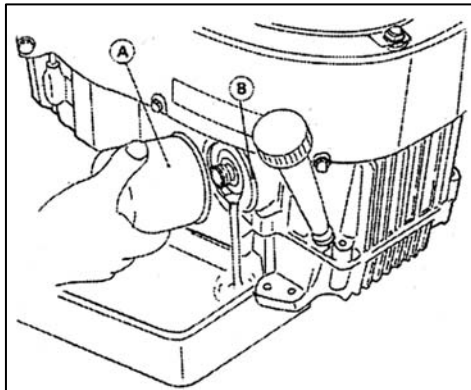
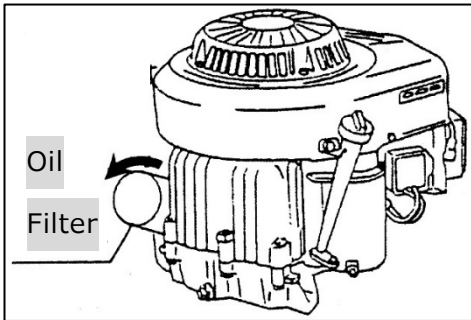

After draining the engine oil, replace the oil filter according to the following procedure.

- ① Remove filter A by turning it counterclockwise.
- ② To prevent twisting, lightly apply new engine oil to the gasket (O-ring) of the new filter with your fingertips.
- ③ Turn the filter clockwise and screw it in until the gasket begins to contact mounting surface B. Then screw it in 3/4 turns.
- ④ Add new specified oil from the oil filler port.
- ⑤ After checking the amount of oil on the level cage, securely tighten the oil filler plug. <
- ⑥ After running the engine at low speed for about 2 minutes, check the oil filter mounting surface for oil ooze.
- ⑦ Stop the engine, check the oil amount again, and if it is insufficient, add it.



Caution

Replace the oil filter by hand without using a tool.

Replace the oil filter once every two engine oil changes or every season.

5.1.4 HST oil check and change

◎ Inspection / supply



When checking the amount of oil in the HST oil tank, check the oil gauge window. If the oil level is not on the oil gauge window, open the oil tank cap and add HST oil until the oil level can be confirmed.



Caution

When changing the HST oil, make sure that the HST tank and HST body have cooled sufficiently before starting work.

Immediately after the engine is stopped, the temperature is high and there is a risk of burns.

◎ Exchange



If the HST is operated for a long time, the HST oil will deteriorate and foreign substances will settle inside the unit. To keep your work safe and comfortable, change the HST oil regularly. Also, change the HST oil filter (installed under the HST oil tank) at the same time as changing the oil.

The total oil volume is 5.0L, and the hexagonal size of the HST oil plug is 3/8 (inch). Change the HST oil within the first 30 hours, especially when working in harsh environments. The metal powder inside the HST unit may become clogged inside the oil filter, which may interfere with running (especially during reverse travel).

Reference ;

1) HST oil is also called hydraulic oil and plays an important role in changing the rotation of the engine to drive. In addition, it also has the effects of lubrication, rust prevention, cooling, etc., but if it is not managed properly, it may cause troubles such as Driving system troubles. Use the specified dedicated oil for adding and replenishment.

2) HST oil change guideline.

First time: 30 hours of use After: once a year or every 200 hours of use,

whichever is shorter

(How to judge HST oil visually)

Appearance	Smell	Status	Measures
Clear and no color change	Good	Good	Use as it is
Clear and has small black dots	Good	Foreign matter is mixed	Use after filtering
It changes to milky white	Good	Water is mixed	Change oil
Discolored to black	Stench	Oxidized / deteriorated	Change oil



Caution

- 1) At the time of product shipment, wear resistant hydraulic fluid equivalent to VG46 has been added.
- 2) Please consult your dealer when replacing the HST oil. Replacement requires special tools and maintenance skills.

HST designated oil: ISO viscosity grade VG46.

(e.g. mobil oil DTE-25 , Shell oil tellus 46 , Esso uni power SQ46.)

5.1.5 lubrication for each part

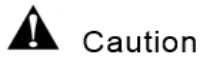
**Caution**

- 1) Grease about every 30 hours, add engine oil (# 30) to other moving parts as needed. Neglecting to lubricate the grease may cause damage due to poor lubrication. Lubricate with reference to the grease nipple in the figure below.
Recommended grease consistency number: No. 2
- 2) A grease nipple is provided on each shaft. You can inject grease with a grease gun, but if you do not have it, please ask to your dealer shop.

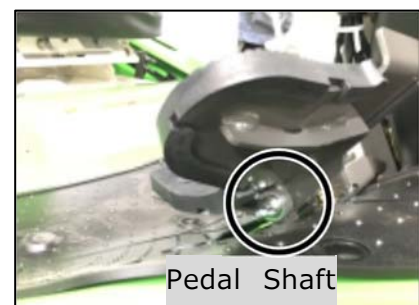
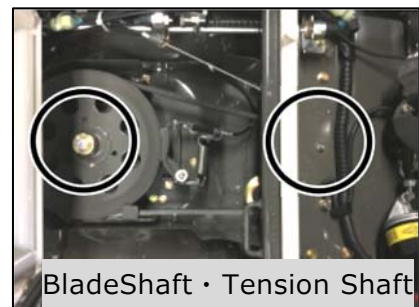
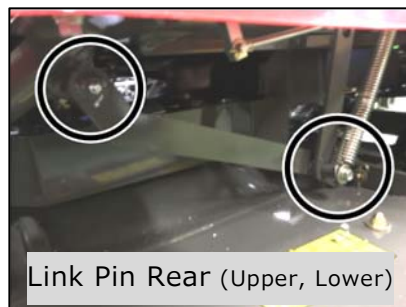
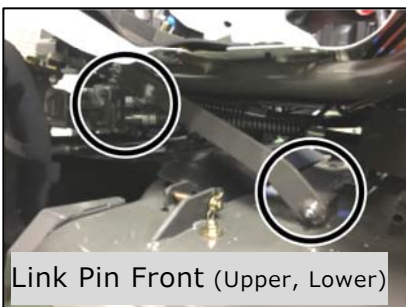
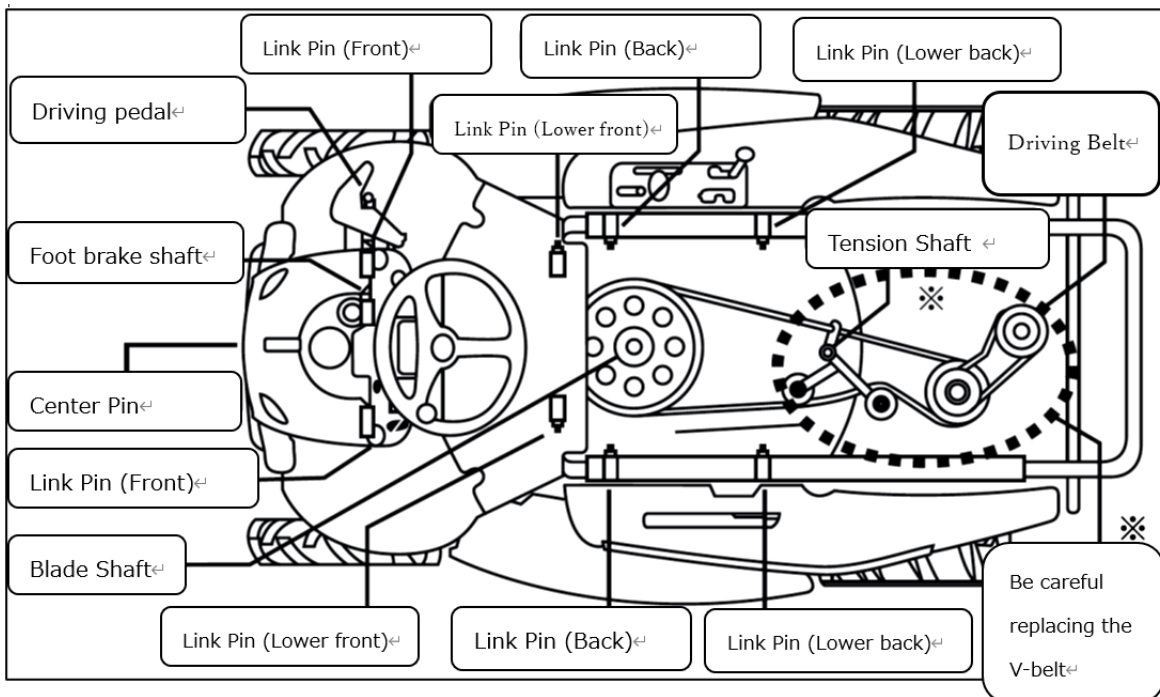
Grease nipple position

5.2 Engine related part cleaning, inspection and adjustment

5.2.1 Cleaning the air cleaner

Warning

- 1) If the air cleaner / recoil starter is clogged with grass debris, etc and continues to work, not only will the output be insufficient and fuel consumption will increase, but the exhaust gas temperature will rise, then causing a fire, which is extremely dangerous.
Be sure to inspect and clean regularly.
- 2) Do not start the engine without the air cleaner.
Dust may be sucked into the engine, causing engine malfunction and abnormal wear.

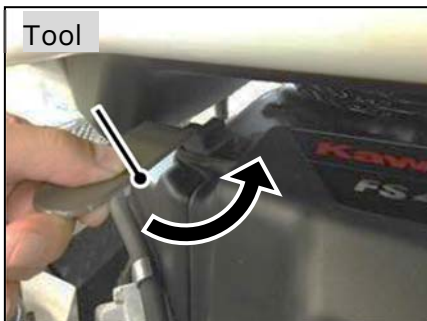

- ① Use the maintenance tool to remove the air cleaner cover.

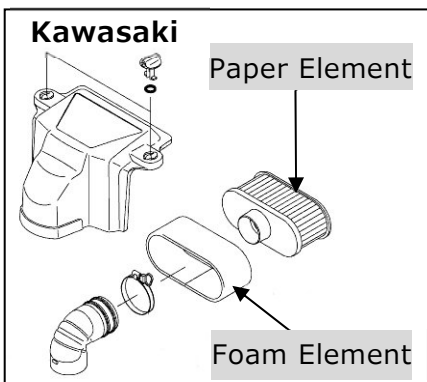

- ② Remove the foam and paper elements, being careful not to let dust or debris enter the vaporizer side.
- ③ Clean the foam element with a detergent and wring it well before drying.
- ④ Tap the cartridge (paper element) or blow air from the inside to remove dust and dirt.
- ⑤ Wipe off any dirt inside the hose with a waste cloth and reassemble.

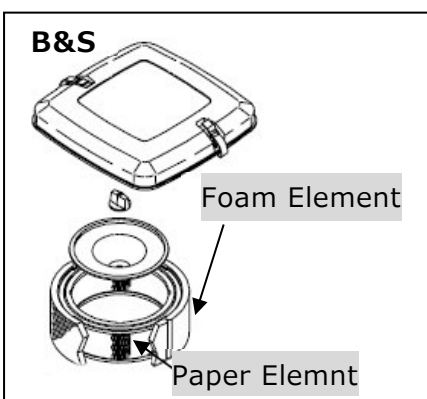

Cleaning and replacing the air cleaner		
	Cleaning	Replacing
Foam Element	Before every	Every 100 hours
Paper Element	Before every	Every 100 hours

Reference ;

- 1) If the paper element is extremely dirty, replace it with a new one, or wash it with soapy water and wash it with water, and dry it thoroughly. Do not pull or tumble the foam element when cleaning. The element is easily torn.
- 2) Be careful when Tapping the paper element please do not make a damage the filter paper.
- 3) When drying, blowing the hot air may damage the adhesive part of the paper element. Dry with low warm air or let it natural dry.
- 4) Be sure to clean it frequently when using it in dusty work environment.

5.2.2 Checking and adjusting the spark plug

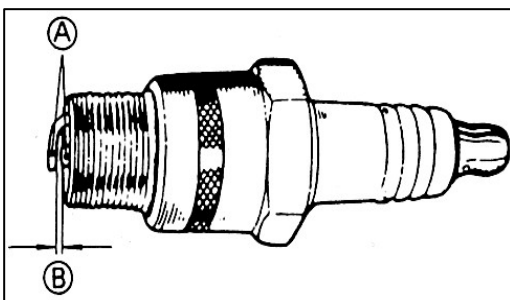

- ① Remove the spark plug with a plug wrench, if there is carbon on the electrode part "A", remove it with a wire brush, and if it is wet, wipe it off.
- ② If the central pottery is cracked or if the electrodes are worn, replace the spark plug with a new one.
- ③ Adjust the electrode gap "B" of the spark plug to 0.7 to 0.8 mm.

Reference ;

- 1) Engine is used V-type 2 cylinder. Check and replace the two plugs at the same time, and do not clean or replace only one side. It may cause engine malfunction.
- 2) When tightening, use a plug wrench to lightly screw in with your hands first (until the gasket touches the bearing surface).
Please note that if you tighten it with a plug wrench from the beginning, the threads may be destroyed.

**Danger**

Do not test the spark plug ignition near the cylinder plug hole. It is dangerous to catch fire.

5.2.3 Check the fuel pipe

**Danger**

This product uses gasoline as a fuel, which may cause fire, if fuel leakage or smoking or bonfire near the machine.

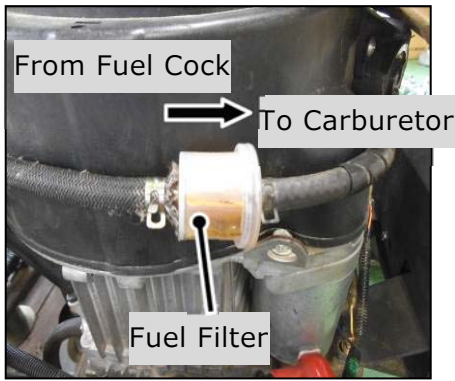

- ① Rubber products such as fuel hoses will deteriorate even if they are not used.
- ② Replace with a new tightening band every 3 years or when damaged.
- ③ Always check for loose or damaged hoses or tightening bands.
- ④ When replacing, be careful not to let dust get inside the hose.

5.2.4 Check the fuel filter

The fuel filter cannot be disassembled and cleaned, so replace it each season or as soon as necessary. Be careful of the insertion direction when replacing.

5.2.5 How to clean the engine cooling system



Warning

- 1) Remove each part after the engine has cooled down, and after cleaning, do not start the engine without installing all parts.
- 2) Continuing to work with grass debris accumulated in the engine cooling system is not only causes overheating, but also causes an increase in engine temperature, which may cause a fire.
- 3) Keep your hands away from the rotating screen. There is a risk of injury.
On models with the Briggs engine, the screen guard rotates with the engine.
- 4) Before each use, remove foreign matter such as mud and grass debris accumulated on the screen guard.

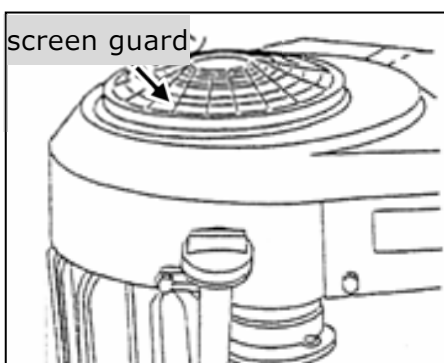

- ① When air blowing, it is easier to discharge grass debris, etc. by raising the sheet.
(Do not use water such as a high-pressure washer as it may cause engine malfunction.)
- ② At the same time, remove grass etc. accumulated on the inside and outside of the HST fan cover. If you continue to use the HST, the HST oil temperature will rise and the original performance of the HST will not be achieved.
- ③ After finishing the work, be sure to return the covers that were removed for cleaning.

5.2.6 How to clean the engine exhaust system

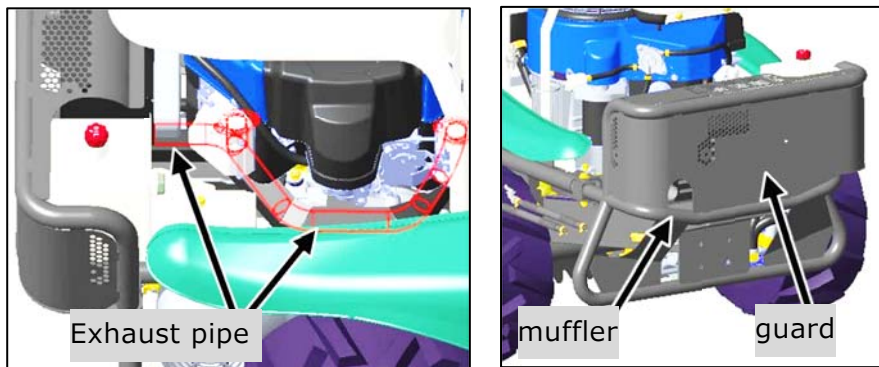

- ① Remove foreign matter such as mud and grass dust around the engine exhaust pipe by blowing air.
- ② Remove the debris that has adhered to the mesh guard, etc. at the rear of the vehicle (muffler).

Warning

- 1) Remove each part after the engine has cooled down, and after cleaning, do not start the engine without installing all parts.
- 2) Continuing to work with debris accumulated in the engine exhaust system not only causes overheating, but also a rise in engine temperature, which can cause a fire.
- 3) Before each use, remove foreign matter such as mud and grass debris accumulated on the exhaust cover and muffler cover.

5.3 Product Inspection and adjustment.

Caution

- 1) When inspecting, servicing, or adjusting work for each part of this product, Set this machine on a flat surface with no obstacles around it, always stop the engine, remove the key, and wait for each part of the engine to cool before starting work.
- 2) Make sure that each control lever operates properly. (At the beginning of each work)
- 3) The wire/ belt will stretch initially, so readjust it after a few hours of operation.
- 4) The wire / belt is a consumable item. If it is abnormal, replace it with a new one.
- 5) Move the machine for a while and check for abnormal noise and overheating.
- 6) Make sure that the bolts and nuts in each part are not loosened and come off, and tighten them securely.
- 7) Be sure to reattach the covers removed for adjustment.
- 8) Please avoid excessive work for the first 2 to 3 hours in order to fully familiarize each part.
- 9) Be sure to perform maintenance after work and regular inspections also.

10) Look around the machine and check each part for oil leaks.

- If you can confirm an oil leak, please contact your dealer shop.
- Continued use with oil leakage is dangerous and may cause damage to the machine.

5.3.1 Wire / belt adjustment for each part

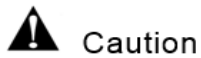

Caution

- 1) Before adjusting the belt /wire /rod, be sure to stop the engine on a wide flat surface, remove the key, set the parking brake, and check the safety sufficiently.
- 2) To adjust the belt and Blade brake, open the seat bracket with your hand and pull it up, and make sure the seat is upright. (If you lift it, it will be fixed in that position.)
- 3) Ask your dealer to replace the blade belt and drive belt. Special tools and techniques are required to replace the belt.

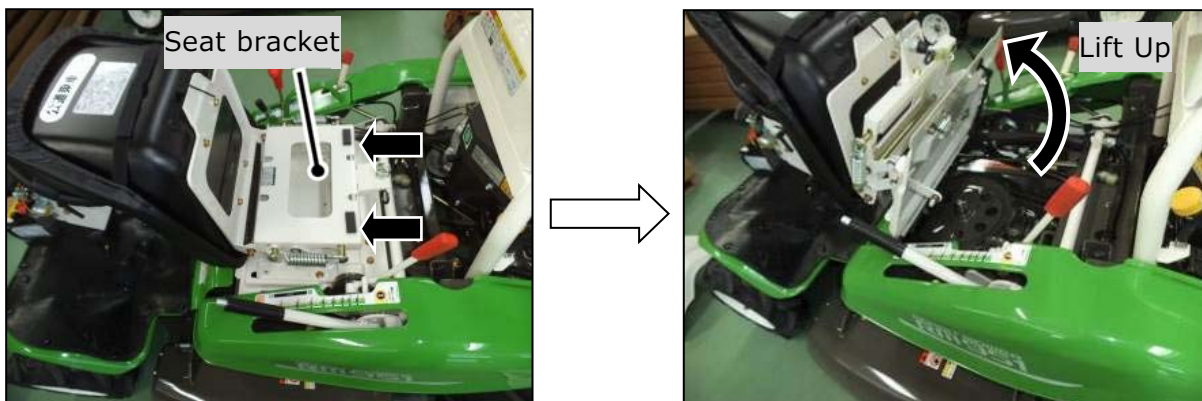

① Drive belt adjustment (bottom of engine)

The Driving belt is always in tension. If the belt slips while Driving, refer to the photo below.

Adjust the tension of the belt by changing the position of the tension spring. Normally, the tension spring is hooked to the third hole from the rear side. When tensioning, hang it on the second hole from the rear side. As a guide, the spring extension is 90 mm when the belt is stretched normally (the free length of the spring is 80 mm).

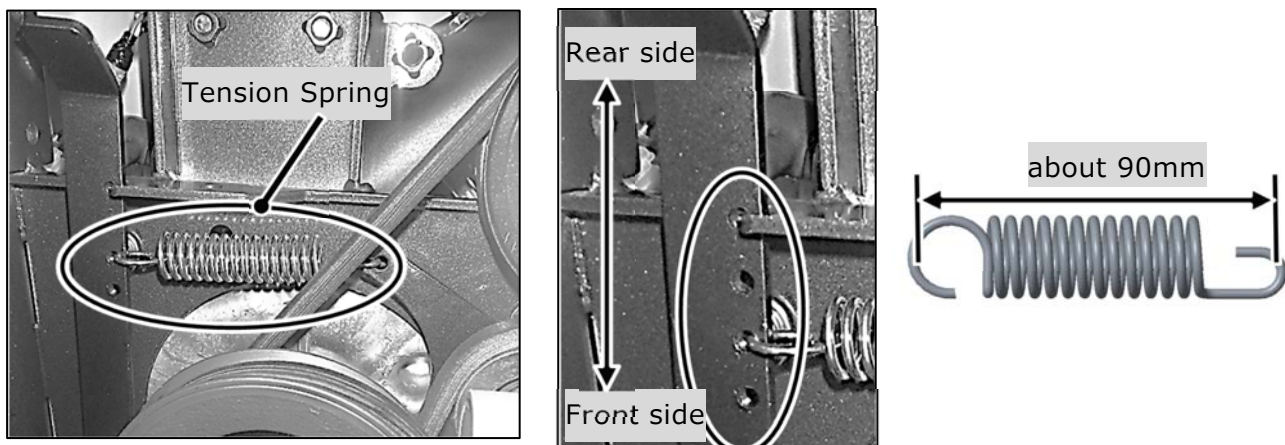

② Blade belt adjustment (under seat bracket)

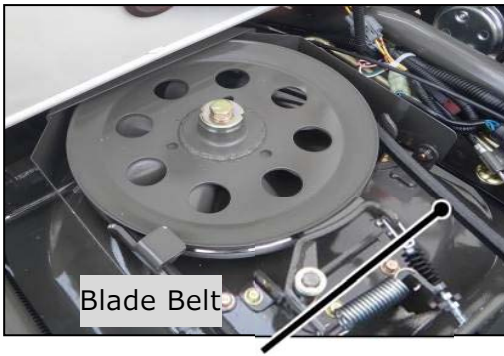

Visually inspect the belt for damage. If it is cracked or worn, replace it with a new one.

③ Adjusting the belt retainer (under the seat bracket)

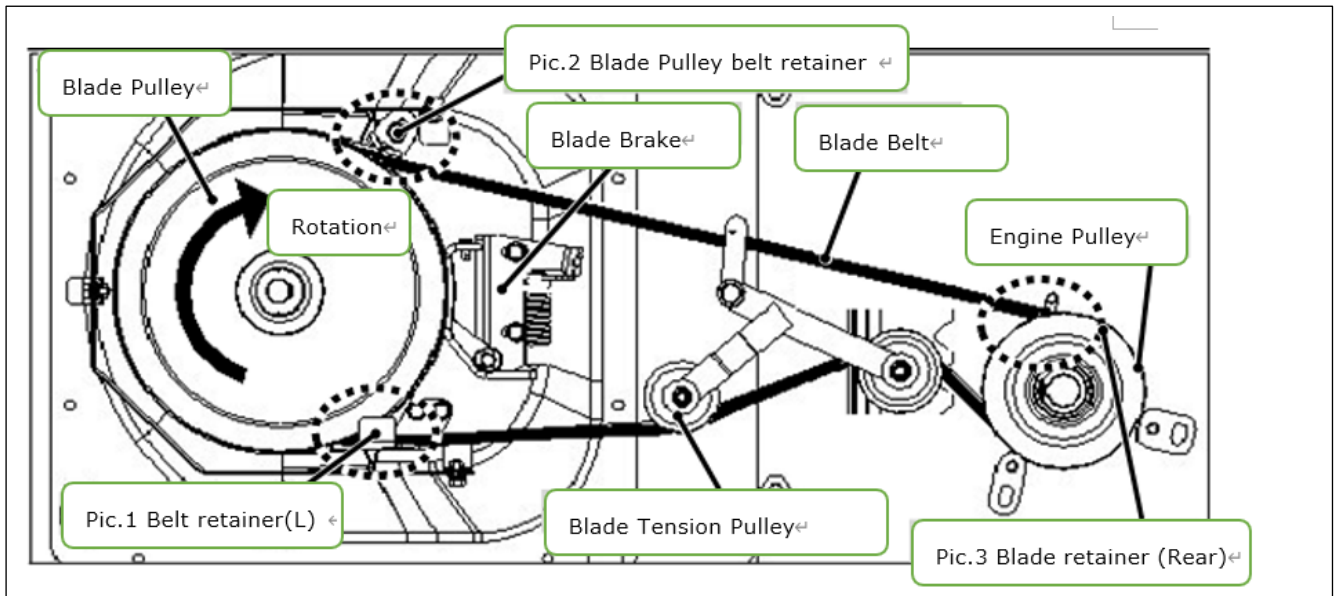

- ① Set the cutting height adjustment lever to the position of about 30 mm.
- ③ Move the Blade clutch lever to the "on" position.
- ④ Adjust the clearance between each belt retainer with reference to the following.

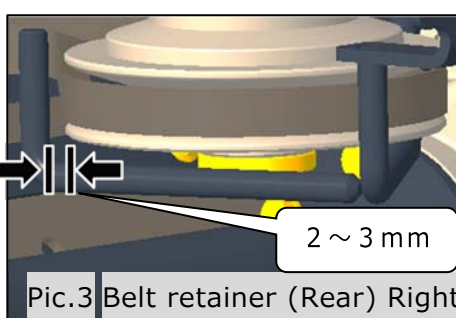
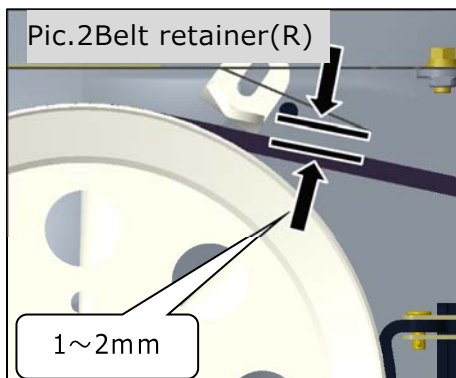
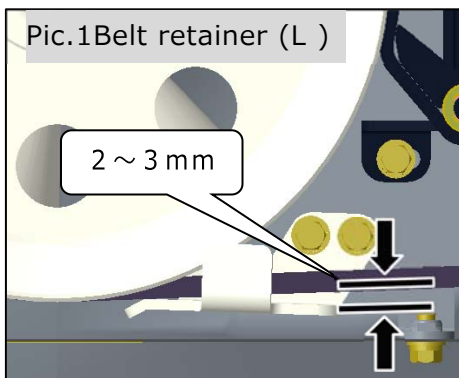

④ Blade brake adjustment

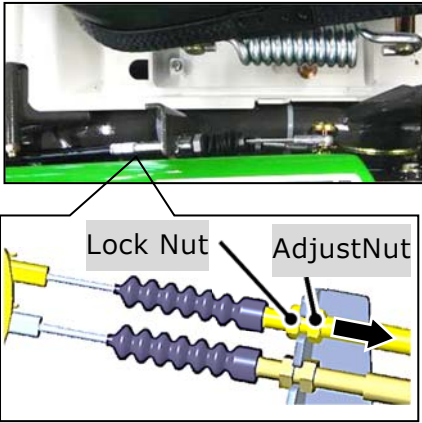

- ① The Blade will stop in about 5 seconds when the Blade clutch lever is in the "off" position. If it does not stop, move the brake wire adjustment nut in the direction of the arrow to adjust. (Brake drag can cause damage to this product.) After adjustment, securely fix with the lock nut.
- ② If it cannot be adjusted, the brake shoes are worn. Please ask your dealer for replacement.

⑤ Parking brake adjustment

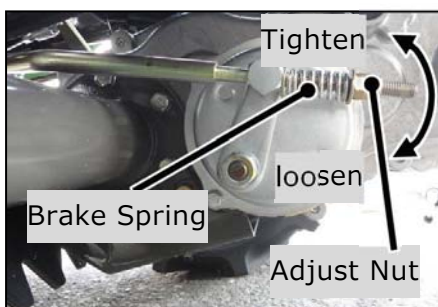

- ① The parking brake is located on the left rear side of the mission and should be adjusted with the brake rod which is connected to it.
- ② The adjustment is made with the adjustment nut at the rear of the brake rod so that the rear wheel "locks" when the parking brake pedal is fully depressed (when the pedal is locked). Turn the adjustment nut clockwise to tighten it and it will begin to operate quickly, and loosen it to slow it down.

Warning

- 1) Not only performance maintenance, but also regular inspection of the braking surface is essential to maintain safety. In the case of the riding type, a serious accident may occur. Therefore, please ask the store where you purchased the product at least once a year to inspect it according to the annual inspection table.
- 2) After adjustment, make sure the parking brake pedal is "locked" and the sub gear shift lever is in the "neutral" position. and the machine dose not move back and forth when pushed it , or it dose not move on slopes.

Caution

Please ask your dealer for the following work.

- 1) The brake will also wear out. If the above method cannot be adjusted, the brake shoes may be worn. For safety, please replace it regularly when the usage time does not exceed 100 hours. When replacing, also replace the U nut and cotter pin at the same time.
- 2) Adjust the play of the brake spring is about 2 to 4 mm, and after adjusting, securely tighten the lock nut.
- 3) The Driving and Blade belt will also be consumed. If it is abnormal, replace it with a new one. First adjustment is 10 hours and then every 50 hours thereafter.。

⑥ Adjusting the Speed shift lever (change pedal)

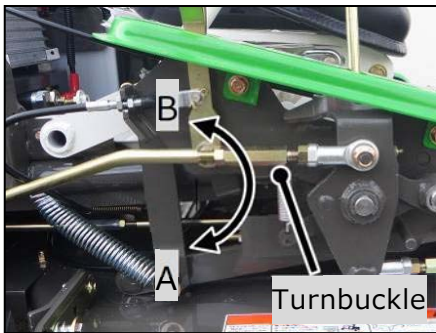

- ② Move the Speed shift lever to the neutral "N" position.
- ② Adjust by turning the turnbuckle connected to the shift lever.
- ③ When moving a little in the forward direction.
...Turn the turnbuckle in direction A.
- ④ When moving a little in the reverse direction.
...Turn the turnbuckle in the B direction.

Reference ;

Adjustment of the speed shift lever (change pedal) is not necessary except when disassembling the mission etc. Adjust if the position of the shift lever is not aligned with the guide display.

⑦ Blade clutch wire adjustment

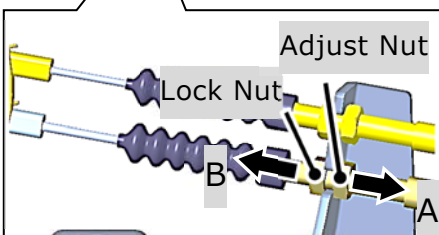

Adjust with the adjustment nut of the Blade clutch wire, referring to the photo on the left.

- ① When the knife belt tension is weak.
...Adjust nut in direction A...
- ② When the Blade belt is tight.
...Adjust nut in direction B...

Spring extension

- ① At the highest cutting height, approximately 125 mm
- ② The lowest cutting height is about 135 mm.

Highest cutting height : About L=125mm

Lowest Cutting height. : About L=135mm

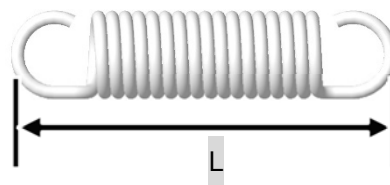

⑧ Diff-lock wire adjustment.

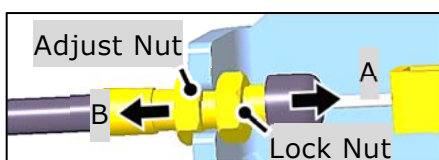

Refer to the photo on the left, adjust with the adjustment nut of the diff-lock wire, and check if it operates properly after the adjustment.

- ① If the differential lock is not work.
...Adjust nut move to direction A...
- ③ If the differential lock is not released.
...Adjust nut move to direction B...

Reference;

Adjust the play at the lever base is about 1 to 3 mm when the differential lock lever is in the "OFF" position (released). Be sure to securely tighten the lock nut after each adjustment.

⑨ Safety switch adjustment.

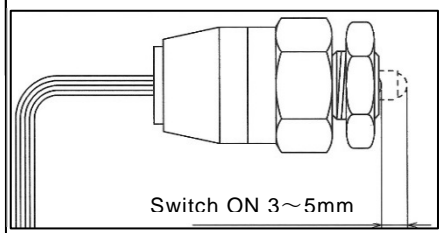

the safety switch.

- ① Safety switches are located on the right side under the seat bracket, the base of the cutting height adjustment lever, and the bottom of the seat total three position.
- ② After adjusting the safety switch, tighten the lock nut and return the seat to its original position.
- ④ Check the operation of the tip of the safety switch, and if the movement is slow, apply a thin layer of grease spray to the switch operating section. If it does not improve, replace

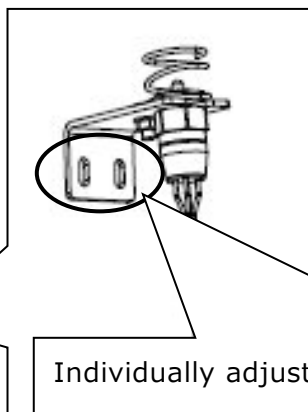
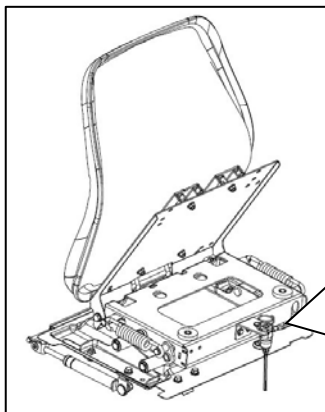

Individually adjusted with the long hole of the seat switch stay.



Caution

- 1) 1) If the engine does not start even though you are sitting on the seat and the cutting height adjustment lever is set to "move" and the parking brake pedal is also locked, adjust the safety switch. The safety switch operates when the tip of the switch is pushed in the range of 3.0 to 5.0 mm, and if the tip of the switch is pushed outside the range, the engine will not start. Adjust the safety switch with reference to the above figure, as the switch itself may be damaged if it is pushed too far.
 - 2) The safety switch under the seat may not be pushed in normally depending on the usage conditions.
- In that case, adjust it individually using the long hole of the sheet switch stay.

5.3.2 Tire Air pressure Adjustment.

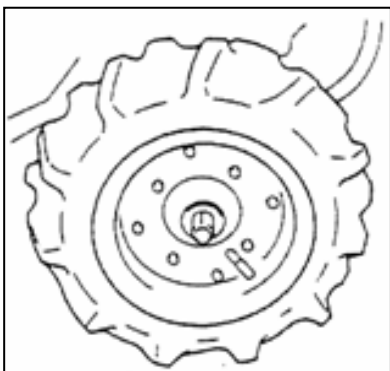

- ① Check the tire pressure of the front and rear wheels according to the table below.



Caution

If the air pressure of the left and right tires is not even, the steering wheel may shake during work.

5.3.3 Front tire inspection

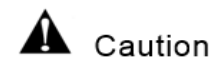

Caution

If dirt or grass gets in from a small gap and leaving it for a long time may damage the wheel of the tire, the oil seal of the front wheel, or the bearing.

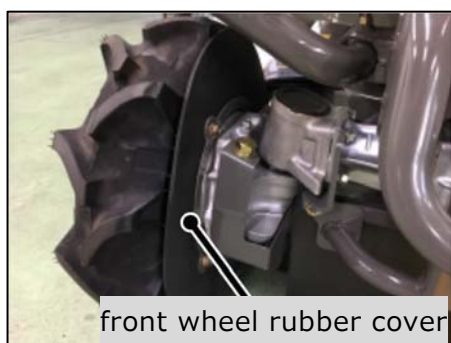

front wheel rubber cover

The front wheel rubber cover prevents the grass from rolling up and dust from entering, but you should remove the front wheel on a regular basis for inspection and cleaning.



Please refer to the picture on the left and lift the front with a jack. Please lift on a flat surface place with the parking brake applied.

	Tire Size	Air pressure (k P a)
Front Wheel	4.00-7	1 2 0
Rear Wheel	17x8.00-8	1 6 0

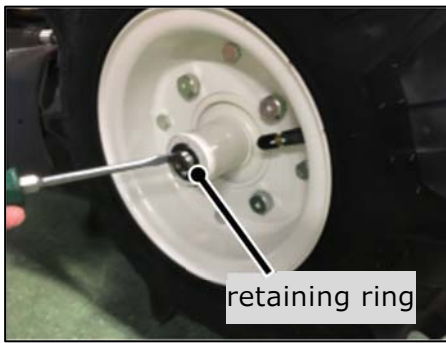

- ① Remove the wheel cap, front axle retaining ring, thrust washer, and tire. Use the screwdriver to remove the front axle retaining ring. When assembling after checking and cleaning, be careful not to forget to put the key.



- ② Clean the inside of the tire wheel. Grease and lubricate the axle when assembling.

5.4 Inspection, replacement and installation of Blade.

■ For your safety, please inspect the Blade and Blade stay before work. ■

Warning

- 1) Since a sharp Blade is used in this machine, be sure to use the "Blade replacement tool" supplied with the product when attaching or detaching the Blade for inspection and replacement, never touch the knife directly with your bare hands using gloves. There is a risk of injury.
- 2) Please specify all parts necessary for Blade replacement including Blade stay as genuine products from the manufacturer. The warranty does not cover failures or accidents caused by using non-genuine products.
- 3) If the Blade hits the root of a curbstone or tree during the work and is impacted, the work is immediately stopped, and the Blade and Blade stay are checked for bends, defects, and wear, and if necessary, please replace them. Before starting work, make sure that the parts to be repaired during the previous work have been properly adjusted.
- 4) If the Blade and Blade stay are wearing, cracks, bends, defects, etc., the Blade suddenly breaks and fly out during work, resulting in serious injury or injury to the worker or others nearby.
- 5) The Blade stay will be consumed as well as the Blade. Even if you do not see any bending or wear, replace it every 100 hours or every 2 years, whichever comes first.



Warning

- 6) Blade rotates at high speed. If the Blade is chipped or broken even a little, it will cause vibration. Not only is it dangerous to continue working while vibrating, but it can also cause cracks and cracks in various parts of the product, significantly shortening the life of the product.
- 7) Replacing the Blade stay requires special tools and maintenance skills. For replacing work, please ask your dealer. At the same time, the cap nut and Blade stay set bolt must be replaced.
- 8) When replacing the Front and Back of the blade, be sure to replace the Blade setting bolt when replacing the blade, and at the same time replace the other parts including the Blade set bolt (hard lock nut, nut guard, knife collar) at the same time, never substitute other bolts and nuts.
- 9) Replace two blades at the same time. Replacing only one side and mixing old and new blades may cause abnormal vibration.

Caution

- 1) Blade replacement work must be done by a person with suitable tools and maintenance skills.
- 2) The cap nut will also wear. When polishing up the Blade, also replace the cap nut at the same time and never substitute another nut.

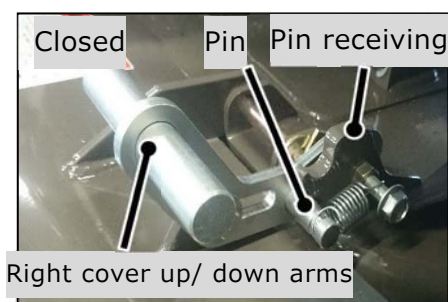
5.4.1 How to open and close the Blade replacement cover.



① Stop the engine and remove the key from the engine switch.

② Set the cutting height to the middle position using the cutting height adjustment lever.

③ Pull the right cover up/down arm outward and pull up the cover.

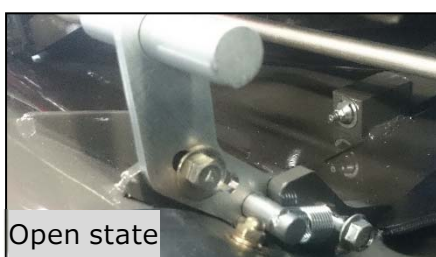

④ The cover can be opened and fixed it by inserting the pin of the right cover up/down arms into the notch on the upper side of the pin receiver.

⑤ To close the cover, pull the up/down arms of the right cover outward, lower the cover, and then insert the pin into the lower cutout.

5.4.2 Check and Replace Blade

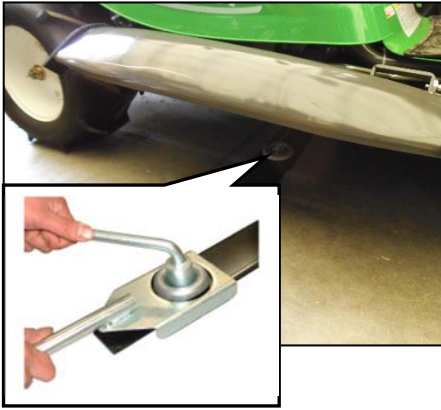

- ① Stop the engine and remove the key from the engine switch.
- ② Set the cutting height to the middle position with the cutting height adjustment lever.
- ③ Fully open the Blade replacement side cover and fix it.
- ④ Check the attachment of the Blade and Blade stay.
- ⑤ Inspect the Blade and Blade stay for cracks, bends and wear.

※ If it is in an abnormal state as shown below, change the Blade. The front and back of the blade stay cannot be replaced. Replace all.

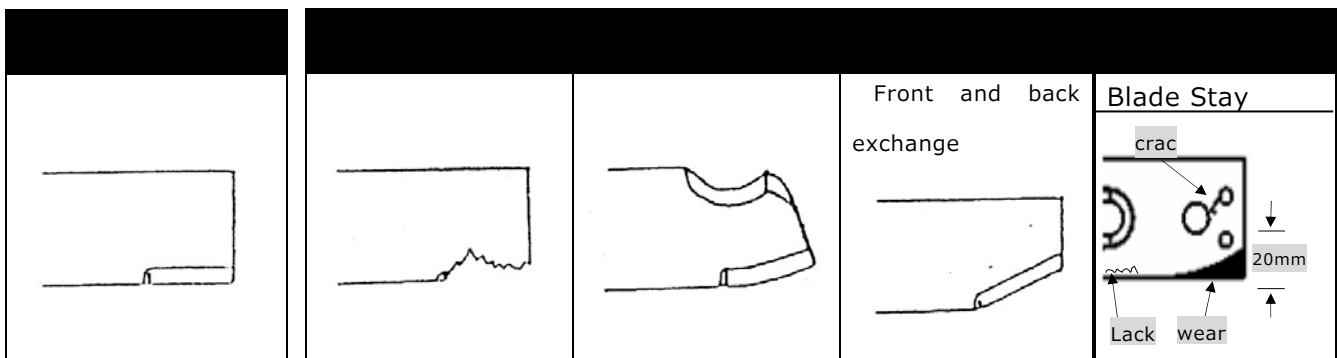

Reference ;

- 1) If you use it in a place containing dry soil or sand, check the Blade frequently because the Blade will wear quickly.
- 2) We recommend that you purchase a set of spare Blades in advance and keep them at hand.

Warning

If the Blade is not installed properly, the Blade may suddenly break and come off during work, resulting in serious injury or injury to the worker or others nearby.

If not replaced, the Blade may scatter during work due to wear, deformation, damage, etc.

5.4.3 How to replace the Blade

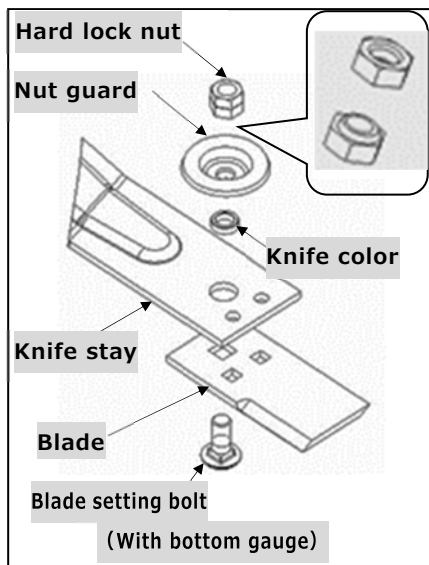

If you need to replace the Blade (both front and back), refer to the following to attach and detach the Blade.

- ① Be sure to use a Blade change and loosen the hard lock nut to remove the Blade. (First, attach the 22 box or box wrench to the upper lock nut only to remove it, and then remove the lower nut as well.)
- ② When replacing the front and back blade, replace the Blade set bolt, and when replacing the Blade, replace other parts including the Blade set bolt at the same time.
- ③ After replacing with a new blade (replacement of the front and back), securely tighten the hard lock nuts one by one in the order of lower side and upper side.

Reference:

- 1) The tightening torque for the hard lock nut is "800 kgf·cm" (78.4 N·m). As a guide, use a 30 cm long box wrench (size 22) and tighten it with a force of about 32 kgf or more.
- 2) A torque wrench is required to check the tightening torque. We recommend that you check the tightening force of the above torque at a dealer in advance.
- 3) If you use it in a place containing dry soil or sand, check the Blade frequently because the Blade will wear quickly.
- 4) We recommend that you have a spare Blades and a set of necessary parts for installation beforehand.
- 5) Be careful not to lose the knife collar when changing Blades.
- 6) If the gauge (recess) on the back of the Blade setting bolt is worn, replace it.

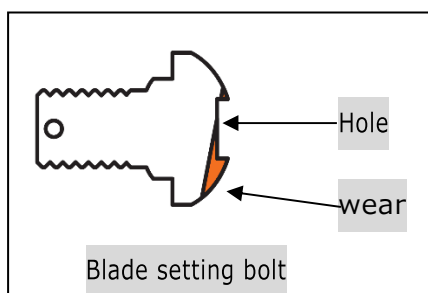

5.5 Long-term storage

5.5.1 Preparation for long-term storage

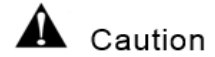

Long-term storage with fuel left in the fuel tank or carburetor may cause problems such as poor starting or reduced output.

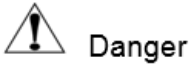

- 1) Since this product uses gasoline as fuel, it is dangerous to ignite for leak fuel, or smoke or bonfire near the product.
- 2) For storage, place the machine horizontally on a flat, well-ventilated place.
- 3) Wait for the engine and muffler to cool after stopping the engine (about 5 minutes or more) before draining gasoline from the fuel tank and covering the machine.
- 3) For safety, please remove the key and store it as the administrator of this product.
- 4) Do not store the removed fuel in a plastic tank or use the oxidized fuel that has been stored for more than 3 months as it may cause troubles.
- 5) Reinstall the removed hoses, clips, and drain bolts.

Reference ;

Storage in cold regions

- 1) In winter, after use, be sure to remove dirt and foreign matter from the machine and park it on a flat, concrete, or hard, dry road surface. The adhered matter may freeze and cause a malfunction.
- 2) On Flat terrain, do not "lock" the parking brake pedal, use "wheel stops" to prevent the brake shoe from sticking.
- 3) If it freezes and becomes inoperable, do not try to force it, but melt the frozen part with hot water or wait until the freeze has thawed. (Please note that we are not responsible for any damage caused by forcibly moving it.)

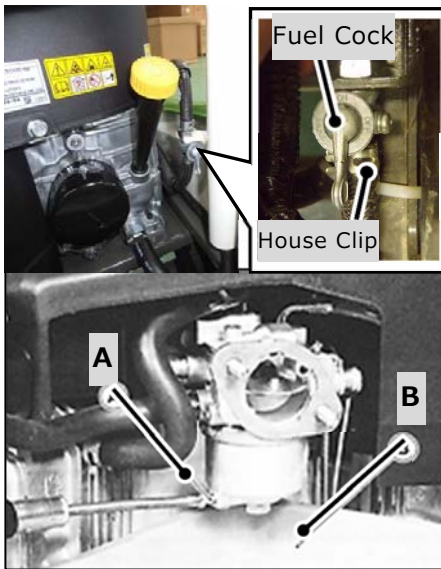

- ① When the machine is not used for more than 30 days, first remove the fuel in the fuel tank from the fuel filler into the container with a pump. Remove the remaining fuel by shifting the fuel hose clip on the tank side of the fuel cock and removing the remaining fuel in to the container B. Next, loosen the drain bolt A of the carburetor with a screwdriver, discharge the fuel in the carburetor to the container B, transfer all the fuel to the designated container, and store it in a dry place.
- ② Clean the engine and the outer surface of this machine. (Reinstall the removed parts as before.)

- ③ Change the engine oil.
- ④ Thoroughly clean all parts. Especially, the grass and dust accumulated around the rotating screen, exhaust system, air cleaner, muffler, HST fan cover, carburetor and belt cover are thoroughly removed by air blowing. Remove the rust from the rusted parts and apply anti-corrosion paint.
- ⑤ Grease and lubricate the greasing and lubrication points respectively.
- ⑤ Engage the parking brake and store the machine Flat place in a well ventilated, dry place.
- ⑥ Check the Engine and Muffler was cooled down when you will put the cover on the machine. Also, periodically check the air pressure during storage and add air if necessary.

Reference ;

- 1) If you start the work with grass and dust accumulated, the engine will overheat due to clogging with grass chips, which may cause burns or a fire.
- 2) The blade cover debris can be easily washed away before it dries by washing it with water pressurized with a hose. At this time, be careful to cover the electrical components of the engine, the carburetor, the air cleaner, and the muffler exhaust port with a cover to prevent water from splashing. It may cause engine start failure.

6. attached list

6.1 Specification sheet (Reference number)

Name		Rabbit Mower	
Model		RM983F	
L×W×H (mm)		2010×1070×950	
Cutting width (mm)		975	
Weight (kg)		345	
Cutting Height (mm)		1 0 ~ 8 0 (Stepless with assistance)	
Blade (Pcs)		Free Blade × 2 & Step stay × 1	
V-Belt (Pcs)	drive	W800 SB 32 × 1	
	Cutting	W800 SB 81 × 1	
Tire Size (Pcs)	Front	4.00-7(φ400) × 2、Tube tire	
	Rear	17×8.00-8(φ450) × 2、Tube tire	
Differential Lock		Equipped	
Handle		Round handle with sub handle. (Adjustable up & down 3 steps / Front & Rear.)	
transmission		H S T Variable speed Transmission	
driving system		4WD (On-demand hydraulic control)	
Mission oil amount (ℓ)		1.0(#90)	
HST oil amount (ℓ)		5.0(VG46)	
Brake		Expansion within the mission, driving and parking brakes	
Speed (km/h)	Forwar	0~10.0	
	Reverse	0~8.0	
Battery		3 0 A - 1 9 L	
E n g i n e	Name	Briggs & Straton	KAWASAKI
	Model	VANGUARD 386777-0140-B 5	FS691V-BG80
	Displacement(ℓ)	0.627	0.726
	Engine Oil (ℓ)	1.7(Full capacity including oil filter)	2.2(Full capacity including oil filter)
	Starting method	Electrical Starter	
	Spark plug (2 pcs)	CHAMPION-RC12YC	NGK - BPR 4 ES (KAWASAKI)
	Fuel tank (ℓ)	12	

※This specification is subject to change without notice for improvement.

6.2 Tool bag details

NAME	Spec / Size	Qty	remarks
instruction manual		1	
		1	
Spanner	10×12	1	
"	14×17	1	
L-type wrench	22mm	1	L-Type box wrench
Protective Gogel	0328-76100	1	Protective equipment
		1	
Setting bolts	M 1 4	2	For Blade front and back replacement
Knife change	"	1	Blade replacement tool
Maintenance tool		1	Cover removal tool
Hex wrench	3/8Inch	1	For HST oil drain

6.3 Consumable item details

Parts Name	Parts No	Pcs/unit	Remarks
Blade	0244-89100	2	
Blade stay	0244-51100	1	
Blade & Set bolt kit	0244-78010	1	
Set bolt kit for Blade setting	0244-78210	2	
Blade Change tool	0244-52400	1	Blade Change tool
Blade Collar	80-1483-818-00	2	
Blade Set bolt	0207-50200	2	M14×32
Hard Lock nut M14	0244-74600	2	Special double nut 1set
Nut guard	0244-51800	2	For M14
Cap Nut	83-1483-175-00	1	Fine nut, M20
Spring washer	89-1750-200002	1	Φ20
Blade stay set bolt	0244-51600	2	8T/M14×30
Spring washer	89-1750-140002	2	Φ14
Battery (30A-19L)	80-1792-976-00	1	
V Belt (Drive)	89-6123-003202	1	SB-32 W800
V Belt (Blade)	89-6123-008102	1	SB-81 W800
Tire tube (4.00-7)	80-1711-404-00	2	Front wheel tire tube
Tire tube (17×8.00-8)	0244-78300	2	Rear Wheel tire tube
Blade clutch wire	0322-75110	1	

6. 附表

Parts Name	Parts No	Pcs/unit	Remarks
Brack shoe set (PA-7)	0244-88100	1	
Blade brack wire	0322-75210	1	
Diff lock wire	0244-72410	1	
Choke wire (Kawasaki)	0348-70200	1	
Choke wire (Vanguard)	0348-70200	1	
Throttlet wire (Kawasaki)	0322-75400	1	
Throttlet wire (Vanguard)	0322-75600	1	
Oil Filter	88-49065-7007	1	Kawasaki (FS691V)
Oil Filter	88-842921	1	B&S Vanguard-23
Air Cleaner Form Element	88-11013-7046	1	Kawasaki (FS691V)
Air Cleaner Form Element	88-692520	1	B&S Vanguard-23
Air Cleaner Cartridge	88-11013-7049	1	Kawasaki (FS691V)
Air Cleaner Cartridge	88-692519	1	B&S Vanguard-23
Fuel Filter Kawasaki	88-49019-0707	1	Kawasaki (FS691V)
Fuel Filter Vanguard	88-691035	1	B&S Vanguard-23
HST OIL Filter	0347-00200	1	For HSToil

7. check list

7.1 Periodic inspection table

★ Failure to perform inspection or maintenance may result in an accident or malfunction. Please perform inspection by referring to this "Periodic inspection table" so that normal functions can be exerted and always in a safe state.

★ Make annual inspection a year, monthly inspection a month, and start-up inspection every time before work.

item	Inspection items	Items to check	Check	S	M	Y	
Braking device	Brake	Parking brake effectiveness	Is there no drag, or is it not lose?	Brake shoe	○	○	○
		Brake rod Joint	Is there deformation or backlash?	Rod	○	○	○
				Joint	○	○	○
		U Nut, W Nut	Is it loose or missing?	U Nut, W Nut	○	○	○
	Split pin	Is it missing?	Split pin	○	○	○	
Cutting device	Cover	Cover condition	No bends, cracks or corrosion. Is the flapper rubber attached properly?	cover	○	○	○
				flapper		○	○
	Rotating part	Blade & Stay (Knife) and installation	Is there any warp or wear? Is the bolt / nut loose, worn, or dropped?	Blade	○	○	○
				Blade stay	○	○	○
	Blade brake	Braking effect (Stop within 5 seconds)	Brake	○	○	○	
Engine	Main body	Acceleration, exhaust, choke operating status.	Acceleration is smooth, exhaust color and odor are normal, and choke operation is smooth?	Acceleration		○	○
				Exhaustion		○	○
				Chock	○	○	○
		Muffler, Battery	Setting is loose or not corroded Is the state of charge of the battery good?	Muffler		○	○
	Battery				○	○	
	Engine body	Is the engine mounted loose and cracked?	Mounting		○	○	
	Air Cleaner	Is it dirty, clogged, torn or scratched?	Air Cleaner	○	○	○	
	Oil	Engine oil, oil filter	Check for quantity, quality, leakage, and foreign matter. Is replacement time appropriate? 【Engine oil: 5H for the first time, change every 50H thereafter, and every 100H filter】	OIL	○	○	○
				Filter	○	○	○
	Oil line	Fuel tube, Filter	Check for fuel leaks, deterioration, deformation, or clogging	Tube		○	○
				Filter		○	○
	Ignition system	Spark plug	Is there any crack in the insulator or carbon accumulation?	Plug		○	○
		High-voltage cord, plug cap	Is there deterioration, cracks, or cracks in the cap?	Cord		○	○
	Cooling	Engine housing	Is there any accumulation of grass debris in the housing?	Inside Cover		○	○
Wiring	Harness	Is it loose or damaged?	Harness		○	○	
Transmission system	Belt	Drive, Blade Belt	Check for tension, cracks, damage, and significant dirt.	Drive	○	○	○
				Blade	○	○	○
	Deceleration	Mission oil	Quantity, quality, oil leakage, foreign matter (water, air) mixing 【Mission oil: 20H for the first time. After that, exchange at 100H】	M-OIL		○	○
Hydraulic	HST Oil (Applicable products)	Quantity, quality, oil leakage, foreign matter (water, air) mixing 【HST oil (equivalent to VG46): First time "Refer to each instruction manual". After that, 200H or exchange once a year. (Replace the HST oil filter at the same time)】	H-OIL	○	○	○	
movable part	Movable state of levers, wires, etc.	Is the operation smooth? Check for sticking or rust.	Diff-lock	○	○	○	
			Cutting part	○	○	○	
			Sub Change	○	○	○	
Speed change	Shift lever	Operation, N position is proper, lose or loose	Lever	○	○	○	
Driving part	Tire (Crawler)	Is the air pressure proper and is there no damage or uneven wear?	Tire	○	○	○	
	Setting state	Check the bolts and nuts for looseness and dropped out.	setting	○	○	○	
Handle	Installation state	Check the bolts and nuts for looseness and dropped out.	Handle	○	○	○	
Instrument	Hour meter (Applicable products)	Is the display time applicable and is the operating status appropriate?	Hour meter			○	
Label	Warning label and nameplate	Adhesion is proper (peeling), damage, dirt	Label			○	

7.2 Engine malfunction and how to deal with it

If the engine is not in good condition, check it according to the table below and take appropriate action.

phenomenon	Cause	treatment	
Starter does not run	Not press the parking brake pedal	Depress the pedal and lock with the stopper	
	Cutting height lever is not in "move"	Cutting height lever set to "moving" position	
	Not sitting on the seat.	Sit on the seat and start	
	Poorly adjusted safety switch	Adjust the switch range to 2 to 8 mm	
	Battery over discharge	Charge with normal current	
	Disconnection of battery cord	Connect the cord	
	Disconnection of coupler wiring	Connecting	
	Fuse blown	Replace the fuse (30A)	
	Harness cut or short	Harness replacement	
Poor charging	Defective charge coil	Replace charge coil	
	Fuse blown	Replace the fuse (charge: 20A)	
	Regulator failure	Replace regulator	
	Battery life	Replace battery	
Difficult to start	Throttle lever is not "low speed" position	Move the throttle lever to "low speed" position	
	Choke lever is not in the "start" or "closed" position.	Pull and close the choke lever when the engine is cooled.	
	Fuel does not flow		Inspect the fuel tank to remove any impurities or moisture that may have settled
			Fuel cock to the "open" (ON) position.
	Fuel filter plugging	Replace fuel filter	
	Air or water is mixed in the fuel line system	Remove foreign matter, inspect the tightening band, and if damaged, replace with a new one.	
	Oil viscosity is high and engine rotation is heavy in cold weather	Use different oil depending on temperature	
	Ignition coil or Unit IS defective.	*Replace the ignition coil or unit	
	Spark plug malfunction		Check the gap between the spark plug electrodes
			Replace with a new spark plug
	Battery is discharge	Remove the battery when not in use, store it in a fully charged room indoors, and install it when using	
	Poor fuel quality	Replace with new good fuel	
Lack of fuel	Refuel		
output is insufficient	Lack of fuel	Refuel	
	Clogged air cleaner	Clean the element	
	Poor fuel quality	Replace with good fuel	
	The Choke is not completely open	Fully return the choke lever to the "open"	
	The cooling system is clogged	Clean around the screen guard	
In case of sudden stop	Lack of fuel	Refuel	
	Fuel cock closed	Fuel cock to the "open" (ON) position	
Exhaust color is abnormally black	Poor fuel quality	Replace with good fuel	
	Clogged air cleaner	Clean the element	
Black color Exhaust came out and output decreased	Clogged air cleaner element	Clean the element	
	Chock is not completely open	Fully return the choke lever to the "open" position	
Blue-white exhaust gas	Too much engine oil	Adjust to the specified amount of oil	
	Cylinder/piston ring wear	* Replace ring	
Engine rotation is not stable	Choke is not completely open	Choke lever move to completely "open" position	
	Poor fuel quality	Replace with good fuel	
EG Stop after a while	Defective ignition coil	* Replace ignition coil	
	Fuel filter is clogged	Clean the fuel filter	
Exhaust gas pungent odor	Poor fuel quality	Replace with good fuel	

7.3 Self-diagnosis table

If any of the following problems occur, refer to the instruction manual and take appropriate action.

Phenomenon	Cause	Treatment
The grass is not discharge well	The grass is wet.	Work after the grass has dried.
	The grass is long.	Increase the cutting height and cut twice.
	The cutting height is low.	Increase the cutting height.
	The engine speed is low.	Set to the maximum speed.
	Working speed is fast.	Reduce working speed.
There is left uncut part.	Working speed is fast.	Reduce working speed.
	The engine speed is low.	Set to maximum RPM.
	Worn or damaged Blade.	Replace with a new Blade.
	Accumulation of grass debris in the Blade cover.	Clean the inside of the Blade cover.
	The grass is long.	Mowing twice.
Mow the grass in the falling direction	Change the mowing pattern (mowing direction).	
Soil cutting occurred.	The cutting height is low.	Increase the cutting height.
	The turning speed is fast.	Reduce the turning speed.
	The terrain has undulations.	Change the mowing pattern (mowing direction).
	There are many undulations on the terrain.	Increase the cutting height.
	Bending of the blade.	Replace with a new Blade.
Belt slips.	Belt tension is low.	Adjust the belt tension.
	There is a foreign object inside the Blade	Clean inside the Blade cover.
	Accumulation of grass on pulley.	Clean the pulley.
	Belt wear out.	Replace with a new belt.
Blade does not stop within 5 seconds	Wear of Blade brake shoes	Replace Blade brake
	Misaligned Blade brake	Adjust Blade brake
Vibration is large.	The Blade is out of balance	Fix the Blade (Both side Blade)
	damage of the Blade	Replace with new blade or fix it
	Accumulate of grass on knife neck	Clean the inside of the knife neck guard
	Knife shaft is bent	Replace knife shaft
	Damaged knife belt	Replace with a new belt
	Bending the knife stay	Replace knife stay
	A mixture of old and new Blades	Do not mix old and new blades
Mowing workload is large	Low engine speed	Increase engine speed
	Work speed is fast	Slow down workspeed
	Wrapping grass around the knife	Clean the knife shaft
	Long grass	Increase the cutting height and cut twice
	Low cutting height	Increase the cutting height
Tire slips and does not go straight	The diff lock is in the "off" position	Set the diff lock to the "on" position
	The field is weak	Stop working until the field is dry
Not stop the shift lever in the "N" position	The neutral "N" position of the shift lever is misaligned	Adjust the neutral "N" position with the turnbuckle of the shift lever
Reduced climbing power	Insufficient tension on the driving belt	Tension or replace driving belt
	Lack of HST oil, deterioration, mixing of air/water	HST oil replenishment, replacement, air bleeding
The unit does not move even if the change pedal is operated	Lack of HST oil	Replenishing HST oil
	HST hose disconnection and tear	Attach hose, replace damaged product.
	Parking brake is not released	Release the parking brake
	Driving clutch lever is in the "off" position	Driving clutch lever move in "ON" position
Parking brake is not effective	Brake shoe wear	Brake shoe replacement
	Oil comes in the brake drum	cleaning and replacing the oil seal
	Water comes in the brake drum	Turn on/off the brake and dry the inside of the drum.
	Tire wear	Replace tires

7.4 Battery maintenance/inspection

Improper handling of the battery can shorten the battery life or cause a serious accident.

Please use with the correct handling method to the full effect.

Warning

- 1) Be aware of short circuits, sparks, and fire when handling the battery.
- 2) Combustible hydrogen gas is generated from the battery. Do not generate fire (matches, lighters, cigarettes, sparks from welders or grinders, sparks on terminals, etc.) near the battery as this may cause a fire or explosion.
- 3) Do not touch the battery with a charged body or clean it with a dry cloth. It may cause a fire explosion due to static electricity.
- 4) Battery fluid is dilute sulfuric acid. Be aware when you touch the eyes and skin as it may be injured. If an accident occurs, act according to [7.4.5 Electrolyte Solution Procedures for Accidents](#).
- 5) Be sure to remove the battery from the unit when charging. It may damage the electrical components or damage the wiring. Fast charging is not a suitable method for supplementary charging. Fast charge is only for emergencies, and for other cases, strictly follow normal charge.

7.4.1 How to replenish the battery fluid

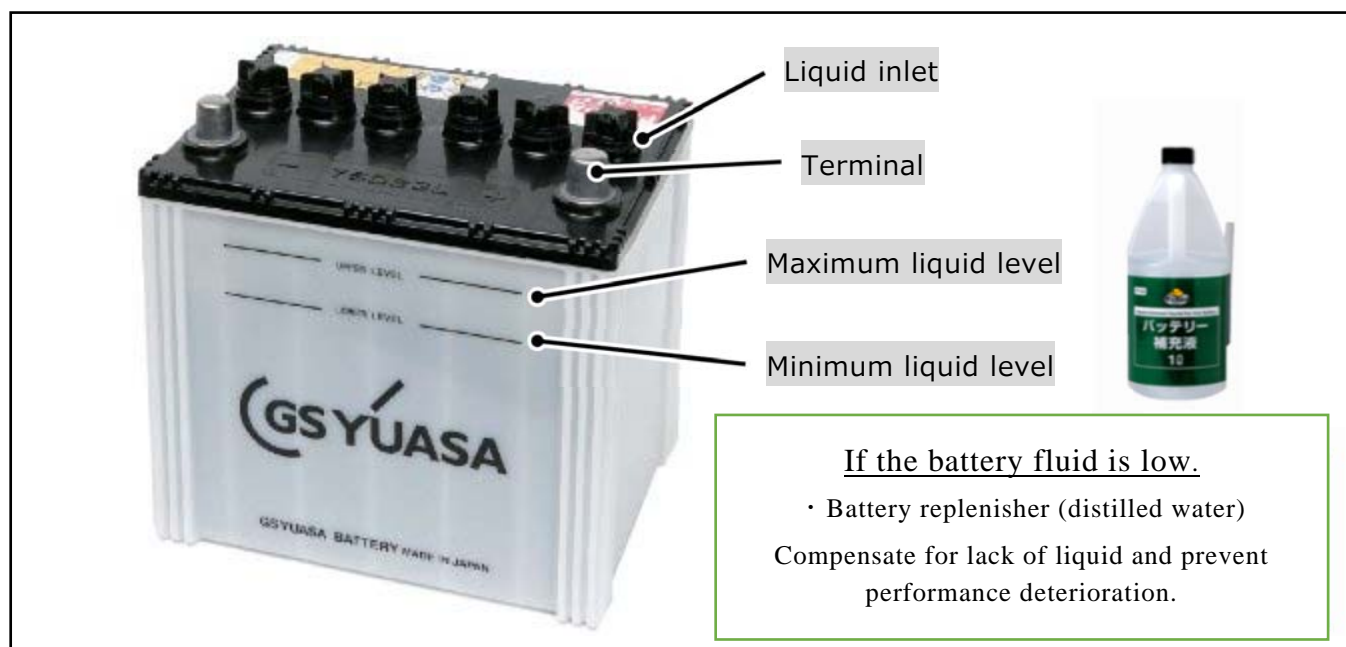

Check the height of the electrolyte in the daily before using. Check the height of the electrolyte once a month even when not in use. If the liquid level drops below half between UPPER and LOWER, add purified water (distilled water) to the UPPER level.



Warning

- 1) The battery electrolyte must not have the below "LOWER" level. It may cause short life, heat generation and explosion.
- 2) Only put purified water into the battery. (Do not replenish with dilute sulfuric acid.)
If impurities are put in, it may cause heat generation, ignition, and generation of toxic gas.
- 3) If too much purified water (distilled water) is put in, the electrolyte may spill and cause metal corrosion. Do not fill more than UPPER (maximum liquid level). If you should spill the battery fluid, be sure to wash it with water.
- 4) After replenishing water, install the inlet port plug firmly so that no liquid leaks.

7.4.2 How to auxiliary charge.

If the engine does not start even if the battery level is controlled, or if the rotation of the starter motor is lower and weaker than usual, the battery was discharged. Follow the procedure below

for charging for 5 to 10 hours.

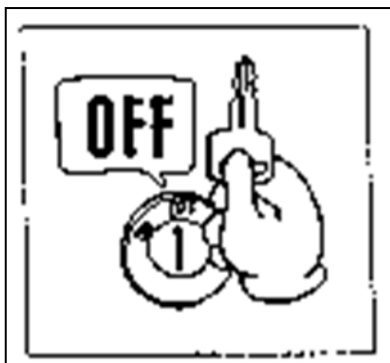

• Battery removal procedure

- ① Stop the engine of this product and remove the key.
- ② Make a note of the battery installation status (terminal polarity position).
- ③ Loosen the bolt on the "-" (minus) terminal of the unit and disconnect the cable terminal from the "-" (minus) terminal of the battery.
- ④ Then, loosen the bolt of the "+" (plus) cable terminal and disconnect the cable from the battery "+" (plus) terminal.
- ⑤ Loosen the battery mounting bracket and remove the battery horizontally. Handle the battery carefully as it is a heavy item.

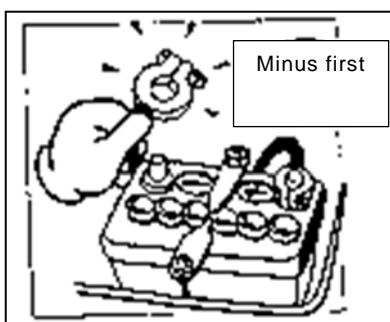

• auxiliary charge ※An optional charger is required.

〈7.4.5 Reference, Battery charging time〉

- ① Before using the charger, make sure that the power is turned off. If it is connected to the battery while it is ON, a spark will be generated, which may cause ignition or explosion.
- ② Connect the + (plus) side of the charger to the + (plus) side of the battery, and the—(minus) side of the charger to the—(minus) side of the battery. Incorrect connection may cause electric circuit failure or wiring damage.
- ③ Take out all 6 liquid inlet cap.

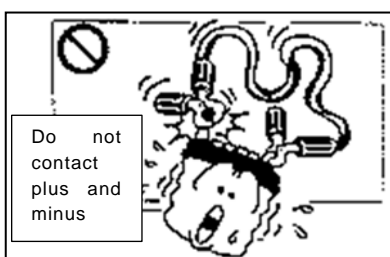



- ④ For supplementary charging, keep the normal charging electrical current and charging time. It may cause liquid leakage, ignition, or explosion.
- ⑤ After completing the charging, attach the 6 liquid inlet cap firmly as before.

Do not use quick charge, as it is not suitable for recovering a battery that has been left for a long time. If it is unavoidable that you want to perform rapid charging, use a charging current that is less than or equal to the rated battery capacity.

Caution

- 1) To use the charger with boost function, follow the charger instruction manual. If handled improperly, it may cause the battery to explode or damage the product and equipment.
- 2) Charge the battery in a well-ventilated area, and keep it away from fire. It may cause ignition or explosion.

Guidelines for charging completion (must satisfy the following conditions)

①	The specific gravity of the electrolyte has been kept constant at 1.270/20°C or higher for 1 hour or longer.
②	The terminal voltage is 15 V or higher and keeps a constant value for 1 hour or longer.
③	Gas is actively generated from each cell.
④	The scheduled charging time has been reached.

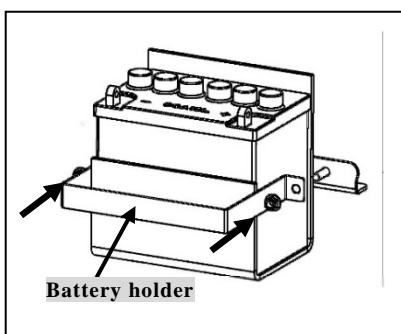

• Battery installation procedure.

- ① Check that there are no foreign objects on the battery mounting base, put them on the mounting base so that the terminals polarity of the removed battery are in the same position, and there is no rattling in the battery holder (applicable model only) or battery fixing stay (applicable model only). fix it firmly.
- ② Attach the + (plus) cable terminal on the unit to the battery + (plus) terminal, and tighten the bolts securely so that there is no looseness.
- ③ Next, attach the machine-side (minus) cable terminal to the battery (minus) terminal, and tighten the bolts securely so that there is no looseness.
- ④ It is effective for rust prevention to apply a thin layer of grease to the metal parts of the cable terminals to prevent rust. If the cable terminals are corroded, clean them with a wire brush or fine sandpaper.

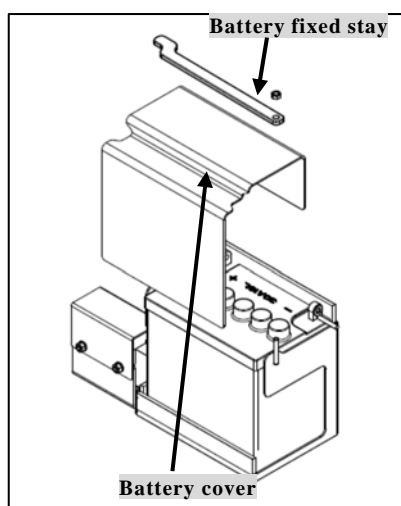

· Start

Start the engine when it is installed in the machine. The start operation should be within 5 seconds, and if it does not start at one time, pause for 10 seconds, or more and then start again. However, if the operation does not start even after performing this operation, the battery life may be suspected. Check the battery and starting circuit.

7.4.3 Battery life

During use, the battery gradually loses its capacity and reaches the end of its life. If the performance does not recover even with supplementary charging, it has reached the end of its life. · The life is shortened by the following factors.

- 1) High temperature (environmental temperature)
 - 2) Frequency of use (too little or too much is affected)
 - 3) Insufficient charging (insufficient supply due to generator failure, etc.)
 - 4) Severe use (usual use in cold regions, insufficient charge, etc.)
 - 5) Inadequate maintenance (when the battery goes up due to failure to check the liquid level of the battery or water supply, contact failure due to loose terminals, forgetting to turn off the engine switch, etc.)
 - 6) Excessive charging (regulator failure, overcharging without finishing charging even after completion time)
- The following signs occur at the end of life.
- 1) The rotation noise of the starter motor is lower and weaker than usual.
 - 2) The amount of electrolyte in the battery decreases quickly.



When any of these signs appear, pay attention to the above and perform supplementary charging. If the sign does not disappear after supplementary charging, it is recommended that you replace the battery as it has reached the end of battery life.

7.4.4 Battery failure and how to deal with it

phenomenon	Cause	treatment	Prevention method
Starter does not turn	Neglected to charge	Charging for a long time with normal charging	Do not use the battery forcibly and charge it early.
	Poor contact of terminal	Thoroughly wash and tighten the terminal	Clean the terminal, tighten tightly and apply grease
	Battery life	Battery replacement	
The starter doesn't run fast. The top of the electrode plate is white when viewed from the inlet hole	Incomplete charging	Charging for a long time with normal charging	Fully charge before use
	Insufficient electrolyte	Recharge by adding distilled water	Regularly check the liquid volume
	Battery overuse (over discharge)	Charging for a long time with normal charging	Do not use the battery forcibly and charge it early.
Can't charge even if charged	Battery life	Battery replacement	3 0 A – 1 9 L
	Fuse blown	Fuse replacement	2 0 A
Corrosion of the terminals is severe and the terminals become hot	Poor contact of terminal	Wash the terminal well and tighten it	Clean the terminal and tighten it firmly and apply grease.
	Dirty terminal		
Electrolyte decreases quickly	The battery case is cracked	Battery replacement	Secure the installation
	Charge voltage is too high	Charger replacement	
	Battery life	Battery replacement	

※If you have any questions, please contact the dealer where you purchased the product.

7.4.5 Treatment method in case of accident with electrolyte

degree of Danger	Accident type	Treatment method
	In case of eye contact	Immediately wash your eyes with a large amount of clean water, and then immediately seek medical treatment from a doctor (ophthalmologist).
	If swallowed	Immediately repeat gargle with drinking water, drink a large amount of fresh water, and seek medical treatment immediately.
	When it adheres to skin or clothes	Immediately rinse with plenty of water, then rinse thoroughly with soap.
	When it adheres to vehicle body.	Immediately wipe off with a waste cloth, then rinse with water.
	When spill it on the floor or the ground.	Sprinkle with sodium bicarbonate (sodium bicarbonate), etc. until no bubbles appear, then rinse with plenty of water.

7.4.6 Estimated battery charging time

A fast-charged battery will discharge quickly. Please follow the charging time below for the battery and fast charge only in an emergency. (Electric current 3 A ~ 4 A)

Specific gravity (20 °C)	charging time (Hour)
1,240 以上	4~5
1,200~1,240	6~7
1,160~1,200	8~9
1,120~1,160	10~12
1,120 以下	15 以上

Specific gravity (20 °C)	Discharged electricity (%)	Residual electricity (%)
1,280(1,260)	0	100
1,230(1,210)	25	75
1,180(1,160)	50	50
1,130(1,110)	75	25
1,080(1,060)	100	0

Caution

- 1) If the temperature of the liquid during charging rises above 45°C (feeling hot to the touch with the palm of the hand), reduce the liquid temperature by halve the current value cahrging or suspend charging, and then charge the battery.