

Parts catalogue

AUTO MOWER

HR665

Serial Number : **CYBBA00001 ~**

MODEL	CODE
HR665	0285-○○○○

CONTENTS

Handle -----	1
Frame -----	3
Transmission -----	9
Rotary -----	14
Engine -----	19
Label -----	20

*Update : **May. 2025***

MEMO

R/P) Recommend Parts

★★ : Highly recommended

★ : Recommended

Painted Parts

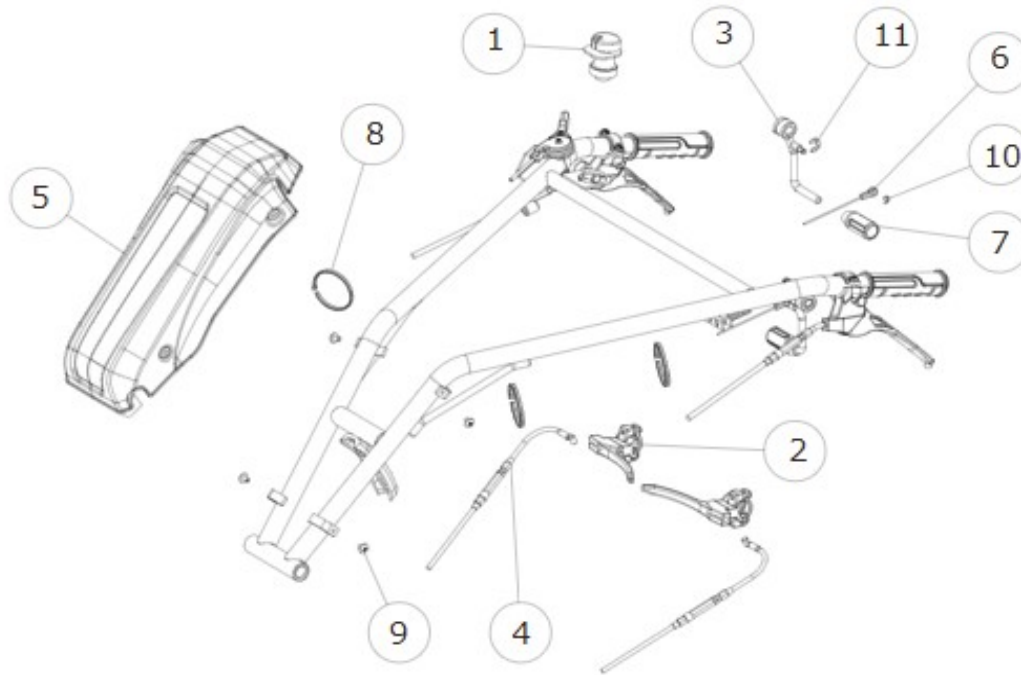

Ref.	Parts Number	Parts Name	Quantity	Remarks	R/P
1	0028-70320	Push Switch ASSY	1		
2	0251-72300	Lever (φ22 φ8)	2		
3	0285-10400	Knife Tension Lever CMP	1		
4	0285-72110	Cable, Handle Up/Down (R/L) (SUS)	2		
5	0285-78200	Handle Bonnet	1		
6	0285-78800	Tension Wire	1		
7	0334-75200	Lever Grip (Red) 10	1		
8	0334-82300	Galva Lock 300	3		
9	89-1159-060108	Truss Mini Screw M6*10	4		
10	89-2521-000050	E Type Ring 5	1		
11	89-2521-000100	E Type Ring 10	1		

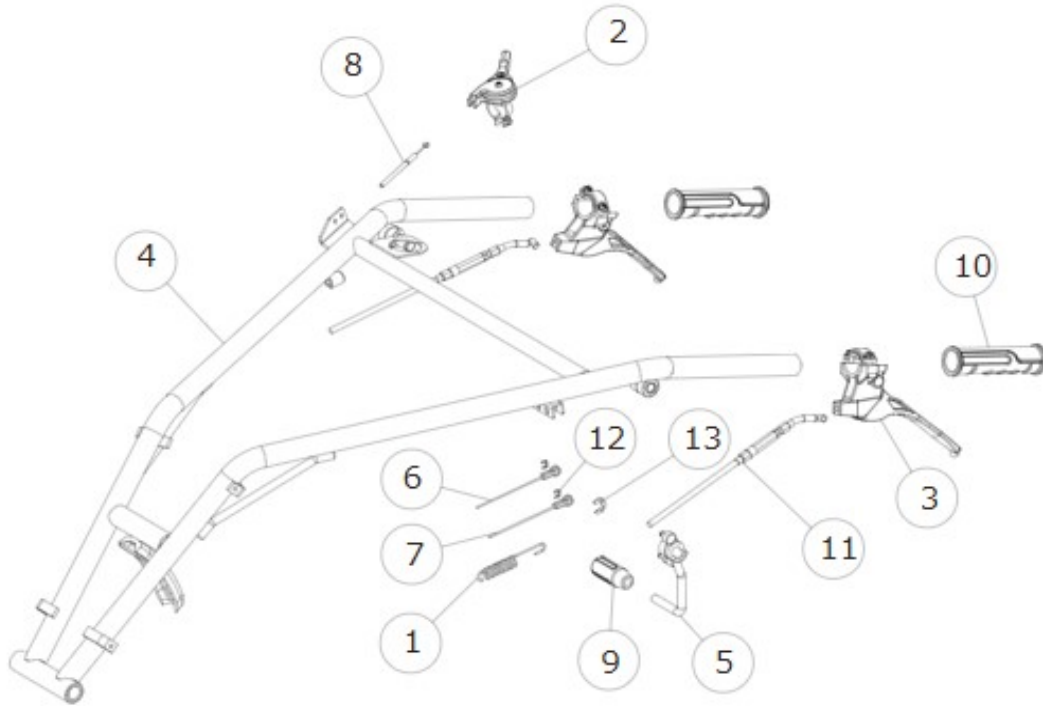

Ref.	Parts Number	Parts Name	Quantity	Remarks	R/P
1	80-1614-248-00	Brake Spring	1		
2	0226-70400	Throttle Lever 27 (Resin)	1		
3	0253-77100	Lever (170-φ27.2)	2		
4	0285-10301	Handle CMP (White)	1		
5	0285-10500	Drive Tension Lever CMP	1		
6	0285-78600	Drive Brake Wire	1		
7	0285-78800	Tension Wire	1		
8	0286-72600	Wire, Throttle(Without Lever)	1		
9	0334-75100	Lever Grip (Black) 10	1		
10	0334-75300	Handle Grip 27	2		
11	0913-71210	Side Clutch Wire (SUS)	2		
12	89-2521-000050	E Type Ring 5	2		
13	89-2521-000100	E Type Ring 10	1		
2+8	0226-70300	Throttle Wire Assy	1		

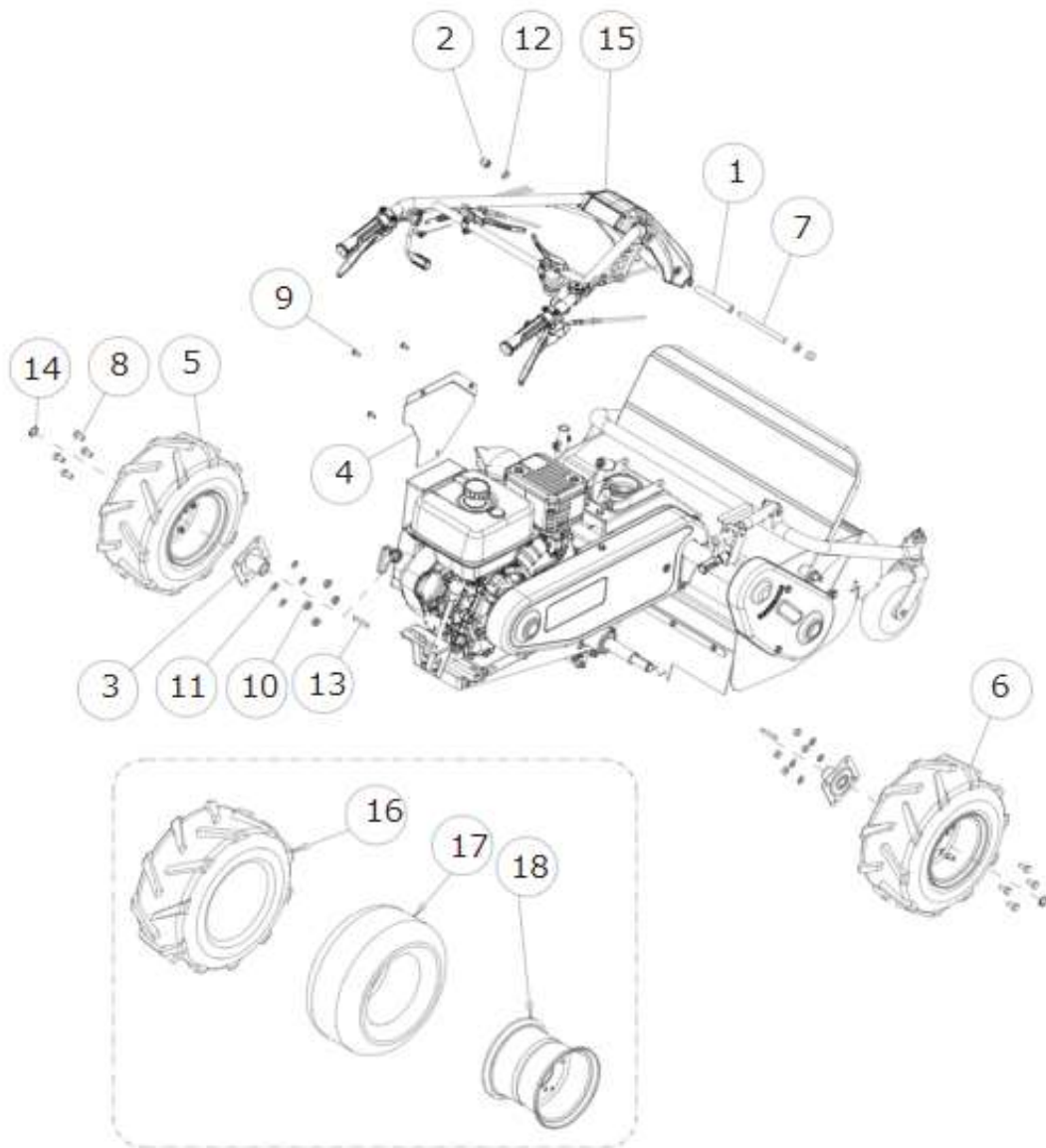

Ref.	Parts Number	Parts Name	Quantity	Remarks	R/P
1	80-1210-222-00	Handle Setting Collar	1		
2	80-1310-228-00	Handle Fix Nut	2		
3	80-1565-413-01	Wheel Boss (White)	2		
4	80-1614-746-1G	Side Cover (Green)	1		
5	80-1761-411-00	Tire Assy (Left) 16*7.00-8	1		
6	80-1761-412-00	Tire Assy (Right) 16*7.00-8	1		
7	83-1210-133-00	Setting Bolt M12*160	1		
8	89-1111-100202	Hexagonal Bolt M10*20	8		
9	89-1137-060152	Hexagonal Bolt (PW) M6*15	3		
10	89-1511-100042	Hexagonal Nut M10	8		
11	89-1750-100002	Spring Washer 10	8		
12	89-1750-120002	Spring Washer 12	2		
13	89-2150-070500	Key 7*50 (round)	2		
14	89-2511-000220	Snap Ring (S22)	2		
15	-	Handle part	1		
16	80-1610-401-00	Tire 16*700*8	2		
17	80-1751-404-00	Tire Tube 16*700*8	2		
18	80-1751-407-00	Wheel Assy 16*700*8	2		

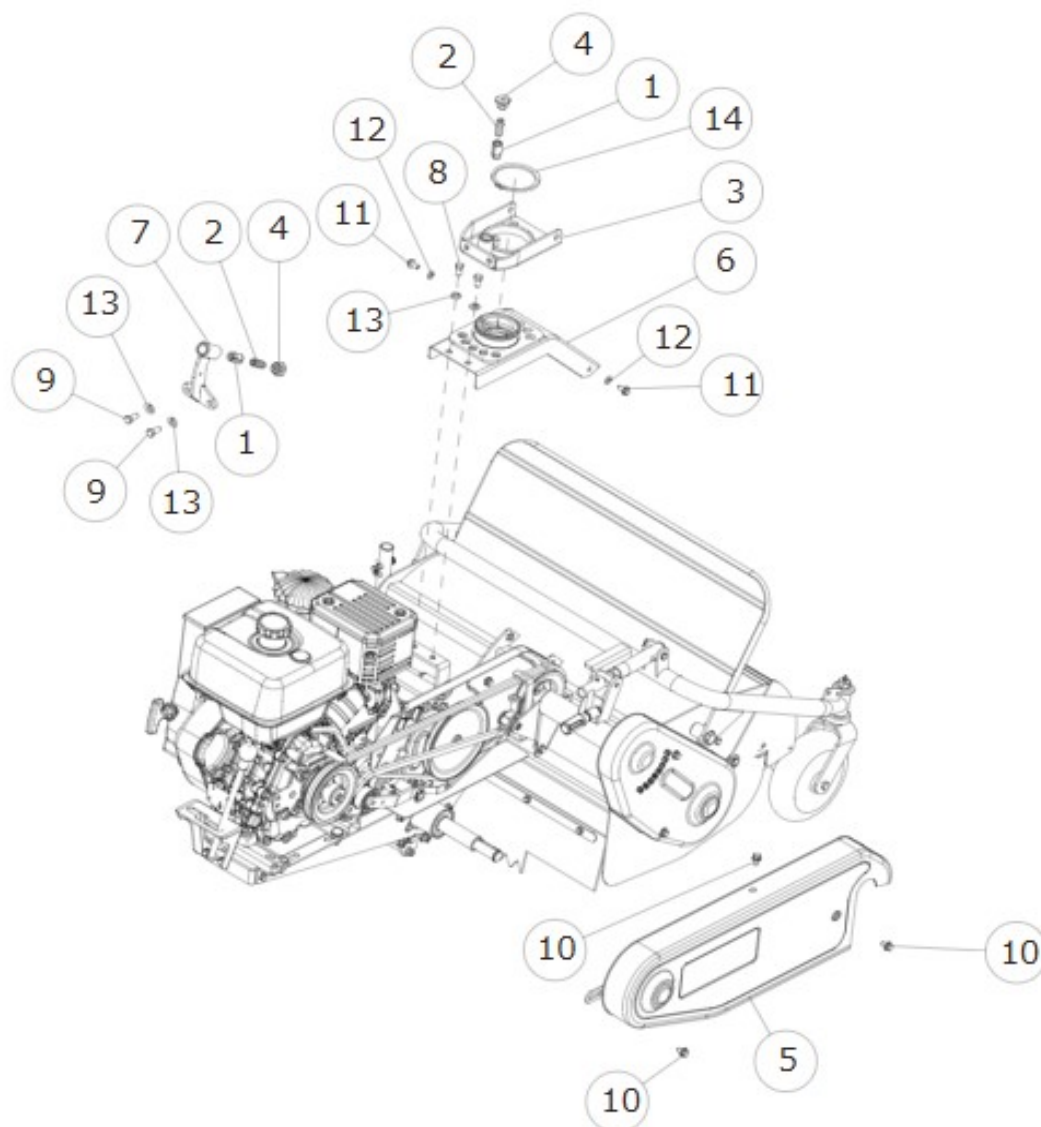

Ref.	Parts Number	Parts Name	Quantity	Remarks	R/P
1	80-1210-216-00	Stopper Pin	2		
2	80-1210-217-00	Stopper Spring	2		
3	0334-2030G	Turntable for Handle (Green)	1		
4	80-1310-215-00	Stopper Cap	2		
5	80-1614-504-21	Belt Cover CMP (White)	1		
6	0285-1010G	Under Bonnet CMP(GX270.340) (Green)	1		
7	0302-1010G	Handle Up/Down Stopper Arm CMP (GX)	1		
8	89-1211-100162	Mini Hexagonal Bolt M10*16	2		
9	89-1211-100202	Mini Hexagonal Bolt M10*20	2		
10	89-1233-080162	Mini Hexagonal Bolt (PWSW) M8*16	3		
11	89-1253-080162	Flange Mini Hexagonal Bolt (8T) M8*16	2		
12	89-1750-080002	Spring Washer 8	2		
13	89-1750-100002	Spring Washer 10	4		
14	89-2511-000850	Snap Ring (S85)	1		

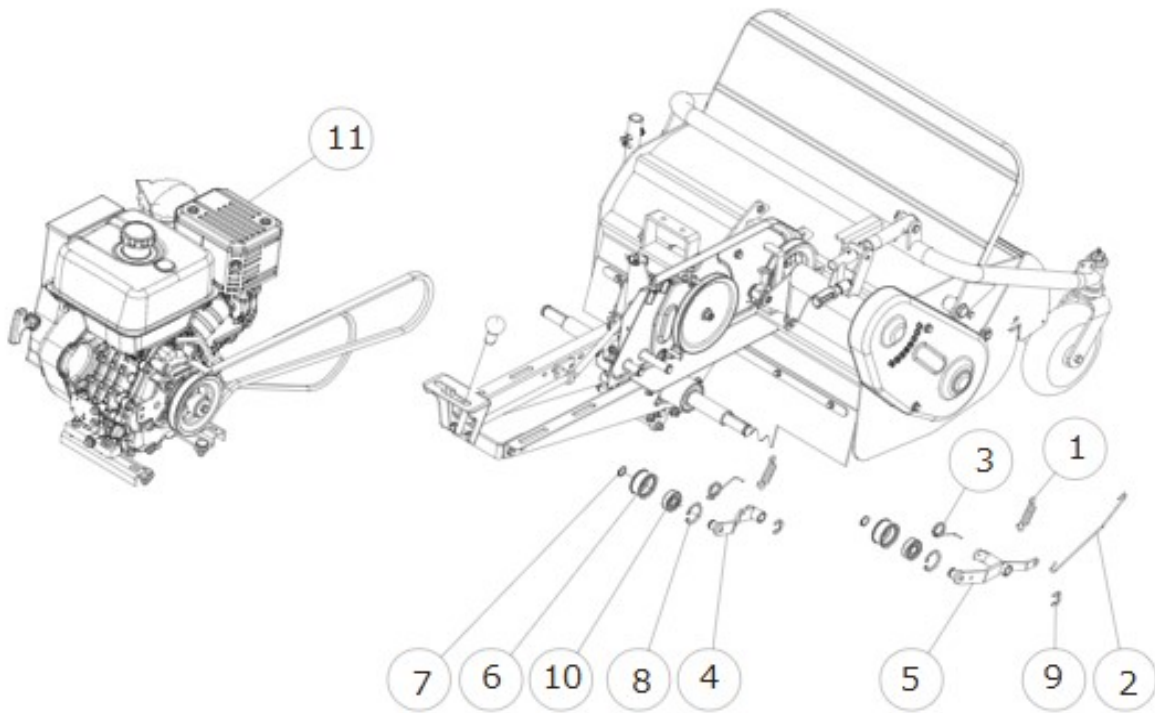

Ref.	Parts Number	Parts Name	Quantity	Remarks	R/P
1	80-1560-551-00	Return Spring	2		
2	80-1614-374-30	Brake Rod	1		
3	80-1614-552-00	Tension Spring	2		
4	0211-54201	Driving Tension Arm (White)	1		
5	0256-40401	Knife Tension Arm (White)	1		
6	83-1032-765-00	Tension Pulley	2		
7	89-2511-000170	Snap Ring (S17)	2		
8	89-2512-000400	Snap Ring (R40)	2		
9	89-2521-000150	E Type Ring 15	2		
10	89-3115-062034	Bearing 6203 2RS	2		
11	-	Engine part	1		
-	83-1032-760-00	Tension Pulley Assy	2	Incl. 6,8,10	

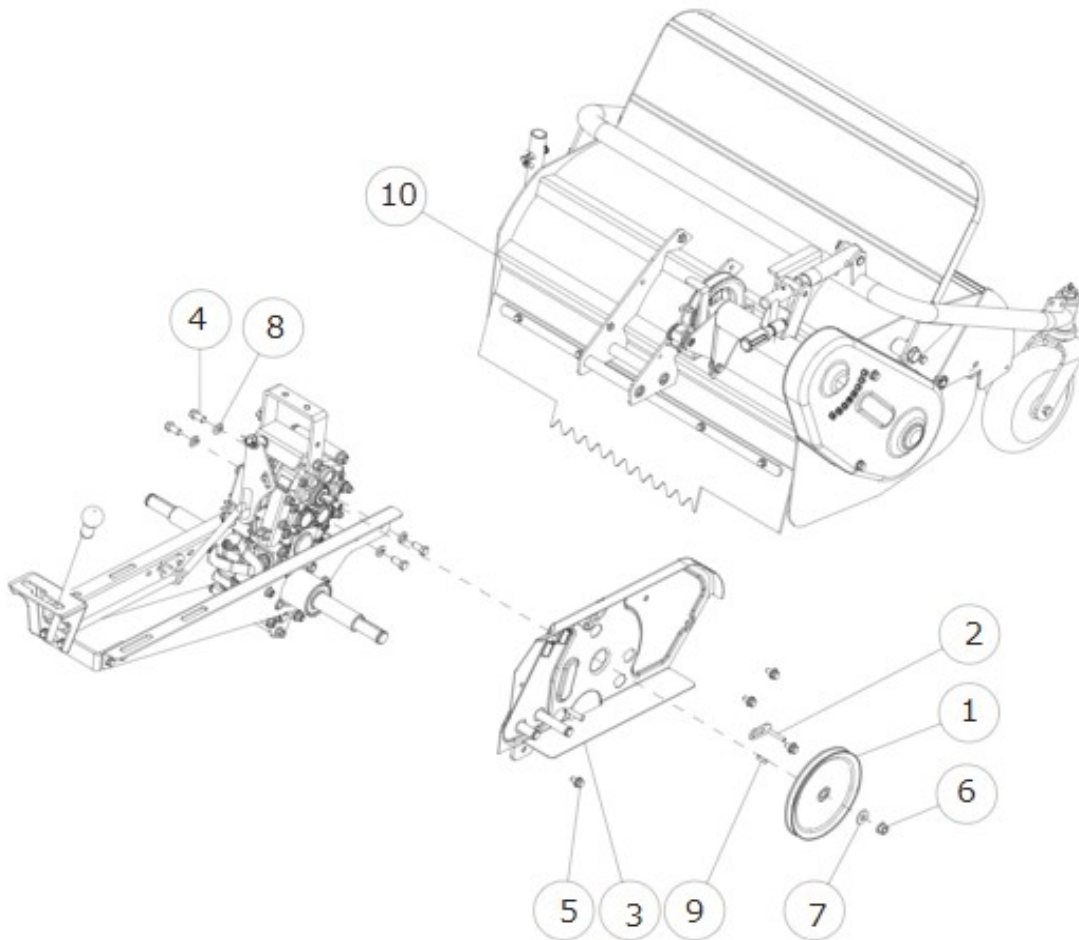

Ref.	Parts Number	Parts Name	Quantity	Remarks	R/P
1	80-1614-521-01	Transmission Pulley (White)	1		
2	0225-40601	Drive Belt Holder CMP (White)	1		
3	0304-62201	Belt Cover Inside CMP (GX270.340) (Wh	1		
4	89-1213-100202	Mini Hexagonal Bolt (8T) M10*20	4		
5	89-1233-080162	Mini Hexagonal Bolt (PWSW) M8*16	4		
6	89-1543-100002	Mini Hexagonal Nut (SW) M10	1		
7	89-1713-100002	Flat Washer 10 (large)	1		
8	89-1750-100002	Spring Washer 10	4		
9	89-2150-050200	Key 5*20 (round)	1		
10	-	Cutting Part	1		

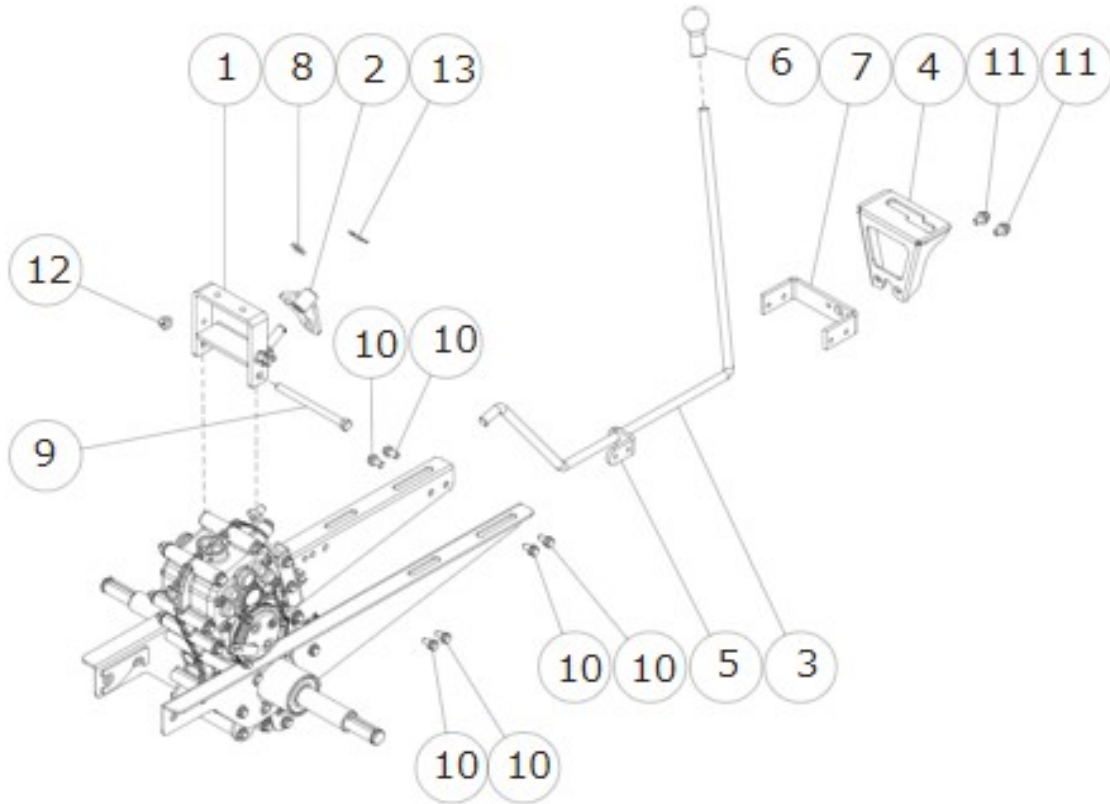

Ref.	Parts Number	Parts Name	Quantity	Remarks	R/P
1	0251-1130G	Change Plate (Green)	1		
2	0251-11601	Change Lever Arm CMP (White)	1		
3	0253-16100	Change Lever CMP	1		
4	0253-22411	Change Guide CMP (White)	1		
5	0253-2250G	Change Rod Setting (Green)	1		
6	0253-79100	Lever Grip 12.7	1		
7	0256-2051G	Rear Bracket (Green)	1		
8	83-1565-329-02	Washer 13*22*2.3	1		
9	89-1213-101302	Mini Hexagonal Bolt (8T) M10*130	1		
10	89-1232-080162	Mini Hexagonal Bolt (SW) M8*16	6		
11	89-1233-080162	Mini Hexagonal Bolt (PWSW) M8*16	2		
12	89-1543-100002	Mini Hexagonal Nut (SW) M10	1		
13	89-2131-120002	Snap Pin 12	1		

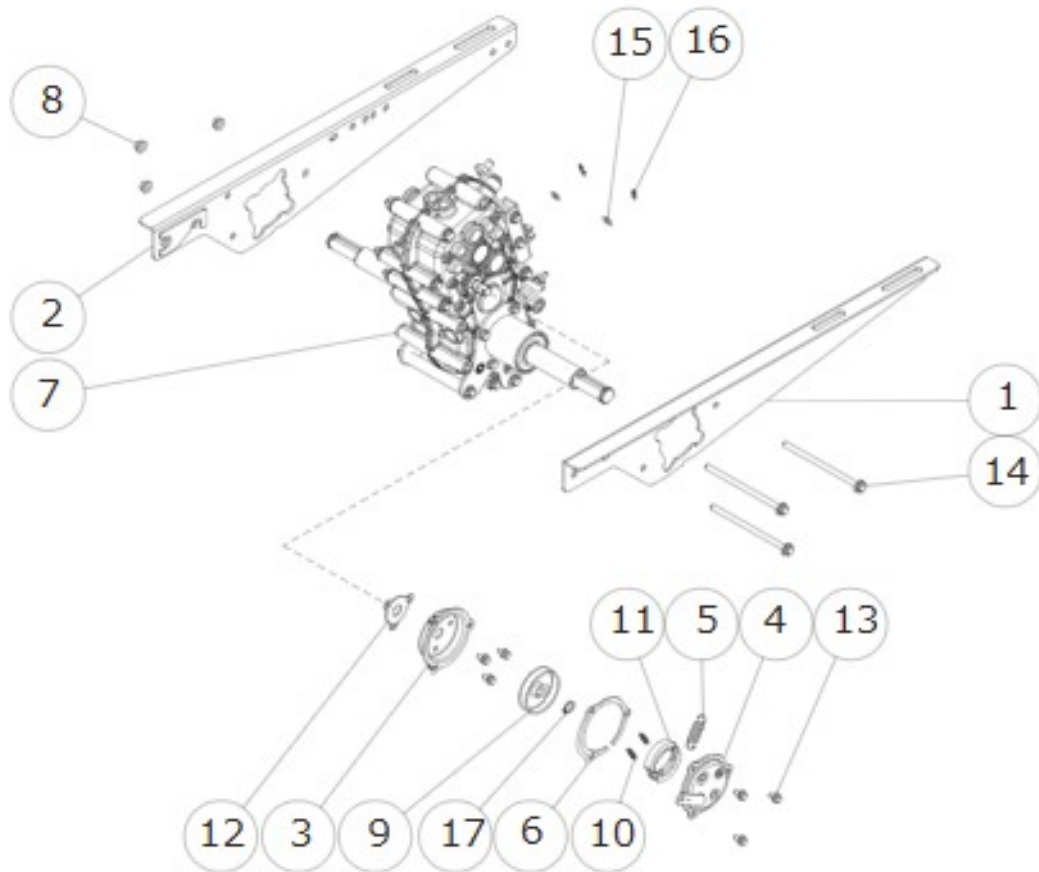

Ref.	Parts Number	Parts Name	Quantity	Remarks	R/P
1	80-1614-301-2G	Main Frame (L) CMP (Green)	1		
2	80-1614-302-2G	Main Frame (R) CMP (Green)	1		
3	80-1614-312-00	Brake Cover CMP	1		
4	80-1614-314-00	Brake Cover	1		
5	80-1614-315-00	Return Spring	1		
6	0211-31800	Brake Packing (Large)	1		
7	0285-09000	Transmission Assy HR662	1		
8	83-1484-255-00	Lock Nut ZUF M8	3		
9	85-1711-315-00	Brake Drum	1		
10	85-1711-317-00	Shoe Return Spring	2		
11	85-1711-318-00	Brake Shoe Set	1		
12	85-1445-317-00	Brake Packing (Small)	1		
13	89-1132-060122	Hexagonal Bolt (SW) M6*12	6		
14	89-1253-081453	Flange Mini Hexagonal Bolt (8T) M8*145	3		
15	89-1711-060002	Flat Washer 6	2		
16	89-2132-060002	Snap Pin 6 (with stopper)	2		
17	89-2511-000140	Snap Ring (S14)	1		

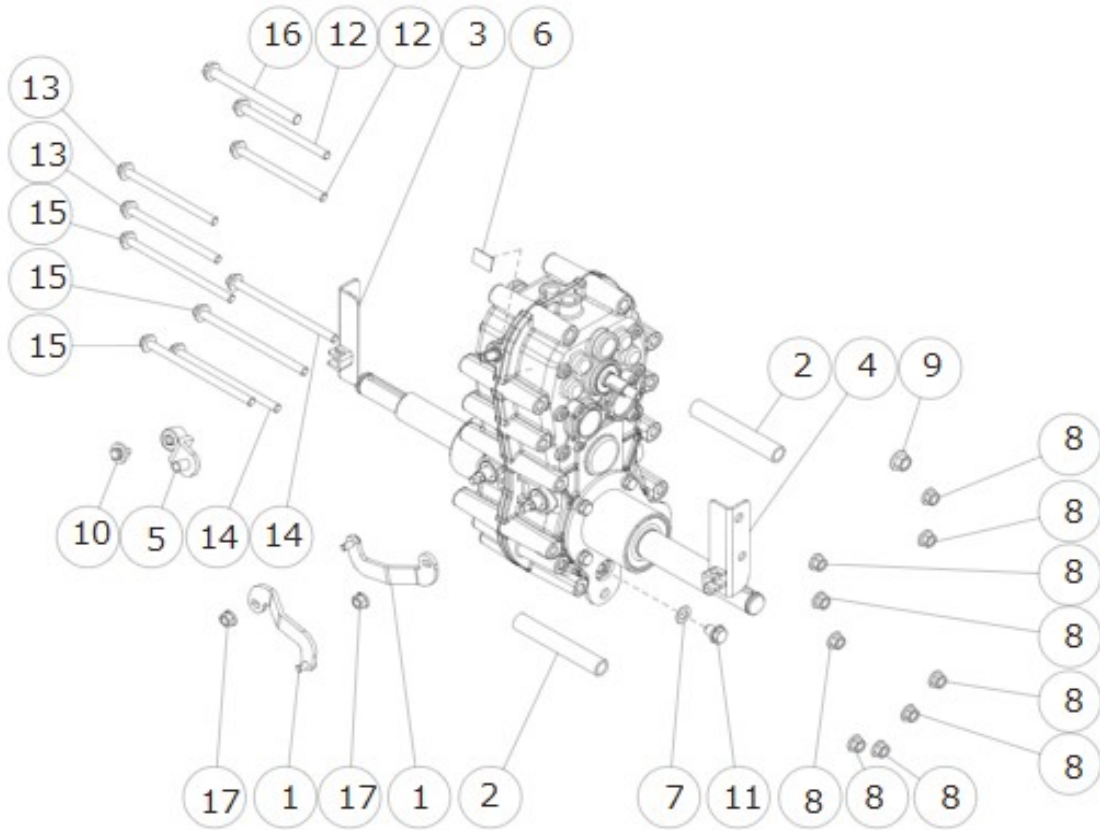

Ref.	Parts Number	Parts Name	Quantity	Remarks	R/P
1	80-1565-153-0H	Side Clutch Arm (Metallic Grey)	2		
2	80-1565-159-0H	Shaft BB Reinforce Pipe (Metallic Grey)	2		
3	80-1565-197-01	Side Clutch Wire Stopper (L) (White)	1		
4	80-1614-198-11	Side Clutch Wire Stopper (R) (White)	1		
5	0251-04301	Change Arm CMP (White)	1		
6	0285-70210	Label, Transmission HR662	1		
7	83-1020-349-00	Copper Packing 10.5*18*1.6	1		
8	83-1484-255-00	Lock Nut ZUF M8	9		
9	83-1493-255-00	Flange Lock Nut M10 (slender)	1		
10	83-1565-111-00	Hexagonal Bolt (with Big Washer) M6*16	1		
11	89-1252-100123	Flange Mini Hexagonal Bolt M10*12 (sler	1		
12	89-1253-081153	Flange Mini Hexagonal Bolt (8T) M8*115	2		
13	89-1253-081203	Flange Mini Hexagonal Bolt (8T) M8*120	2		
14	89-1253-081353	Flange Mini Hexagonal Bolt (8T) M8*135	2		
15	89-1253-081403	Flange Mini Hexagonal Bolt (8T) M8*140	3		
16	89-1254-101153	Flange Mini Hexagonal Bolt M10*115 P=	1		
17	89-1543-080002	Mini Hexagonal Nut (SW) M8	2		

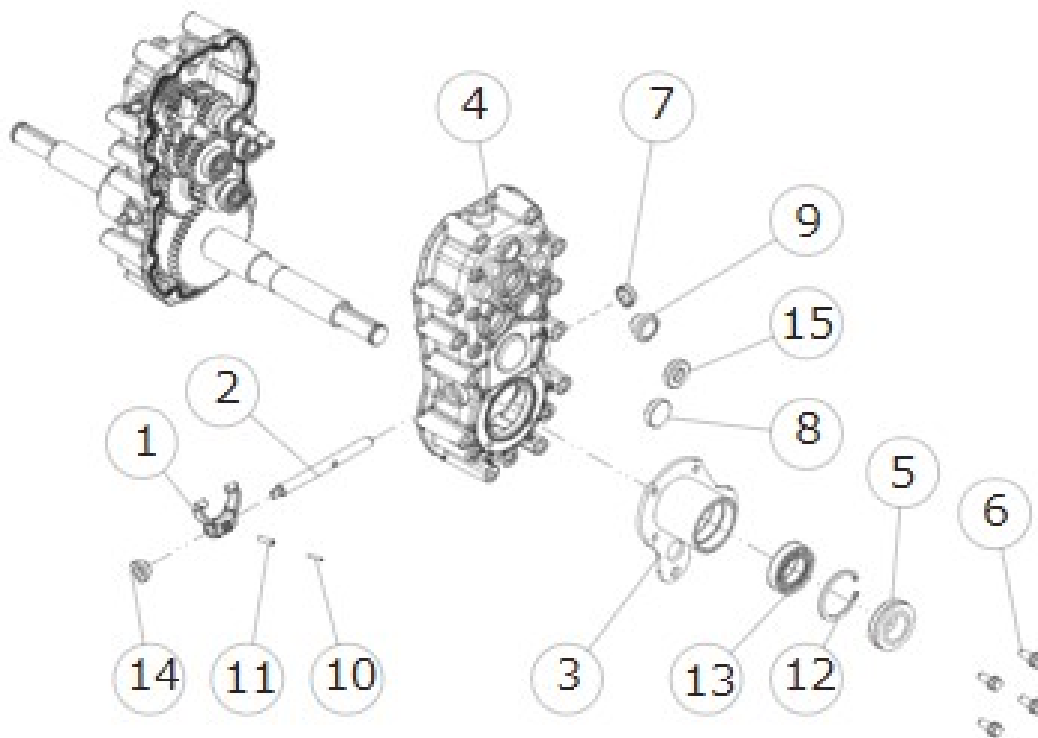

Ref.	Parts Number	Parts Name	Quantity	Remarks	R/P
1	80-1415-114-00	Side Clutch Fork	1		
2	80-1425-112-00	Driving Clutch Fork Shaft	1		
3	80-1565-156-0H	Shaft BB Case (R) (Metallic Grey)	1		
4	80-1614-103-00	Transmission Case (R)	1		
5	0297-08000	Oil Seal AP 35.55.16	1		
6	83-1415-127-00	Seal Bolt (SW) M8*20	4		
7	83-1415-671-00	Blind Cover 22	1		
8	83-1415-672-00	Blind Cover 30	1		
9	83-1517-685-00	Oil Cap 20	1		
10	89-2111-030020	Spring Pin 3*20	1		
11	89-2111-050020	Spring Pin 5*20	1		
12	89-2512-000550	Snap Ring (R55)	1		
13	89-3111-060064	Bearing 6006	1		
14	89-5121-122207	Oil Seal UE 12.22.7	1		
15	89-5121-153007	Oil Seal UE 15.30.7	1		

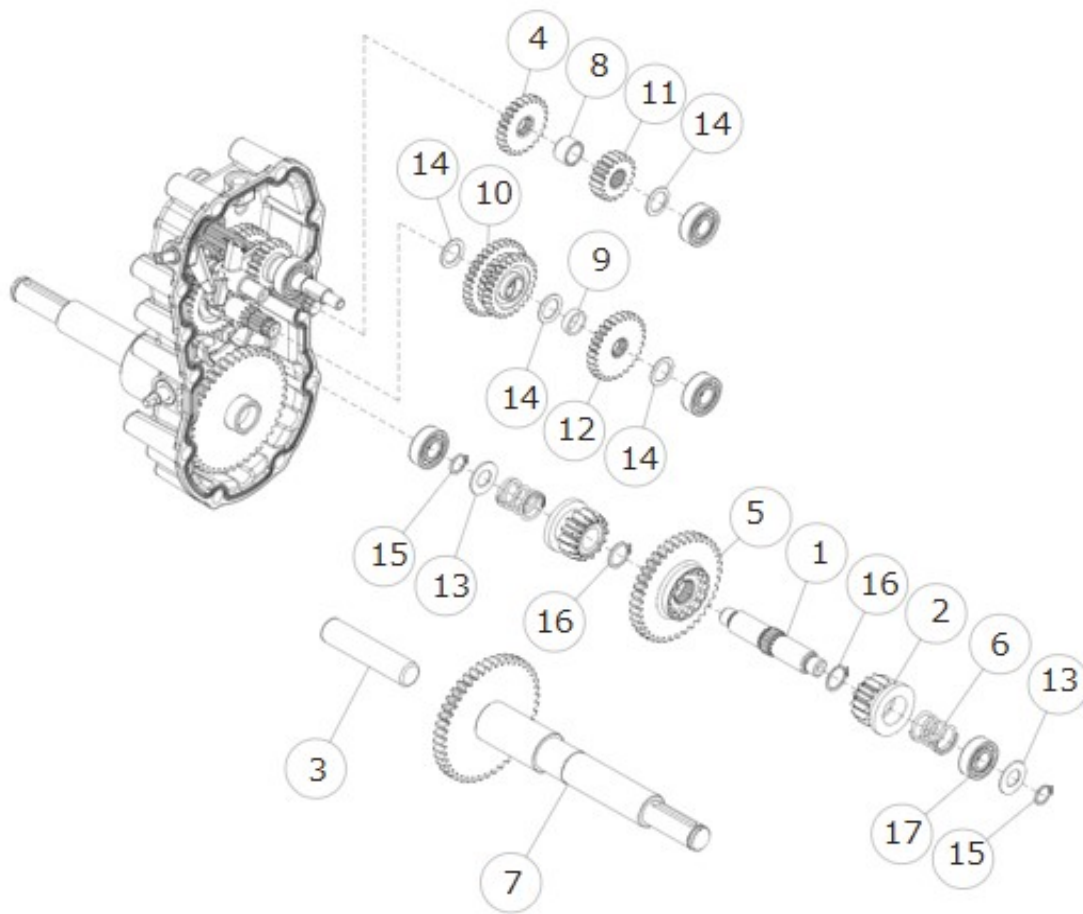

Ref.	Parts Number	Parts Name	Quantity	Remarks	R/P
1	80-1032-140-00	Side Clutch Shaft	1		
2	80-1032-141-00	Side Clutch Gear 14T	2		
3	80-1310-150-10	Shaft Pin	1		
4	80-1575-129-10	2nd Shaft Gear 24T	1		
5	80-1575-142-00	Side Clutch Gear 38T	1		
6	80-1575-162-00	Side Clutch Spring	2		
7	80-1614-146-10	Axle CMP	1		
8	80-1920-130-00	Collar A	1		
9	0223-02500	Collar 6L	1		
10	0251-01610	3rd Shaft Gear 22T	1		
11	0282-00500	2nd Shaft Gear 18T	1		
12	0282-00600	3rd Shaft Gear 28T	1		
13	83-1633-362-10	Thrust Washer 15*30*1.2	2		
14	83-1830-368-00	Thrust Washer 18*26*1.0	4		
15	89-2511-000150	Snap Ring (S15)	2		
16	89-2511-000200	Snap Ring (S20)	2		
17	89-3111-062024	Bearing 6202	4		

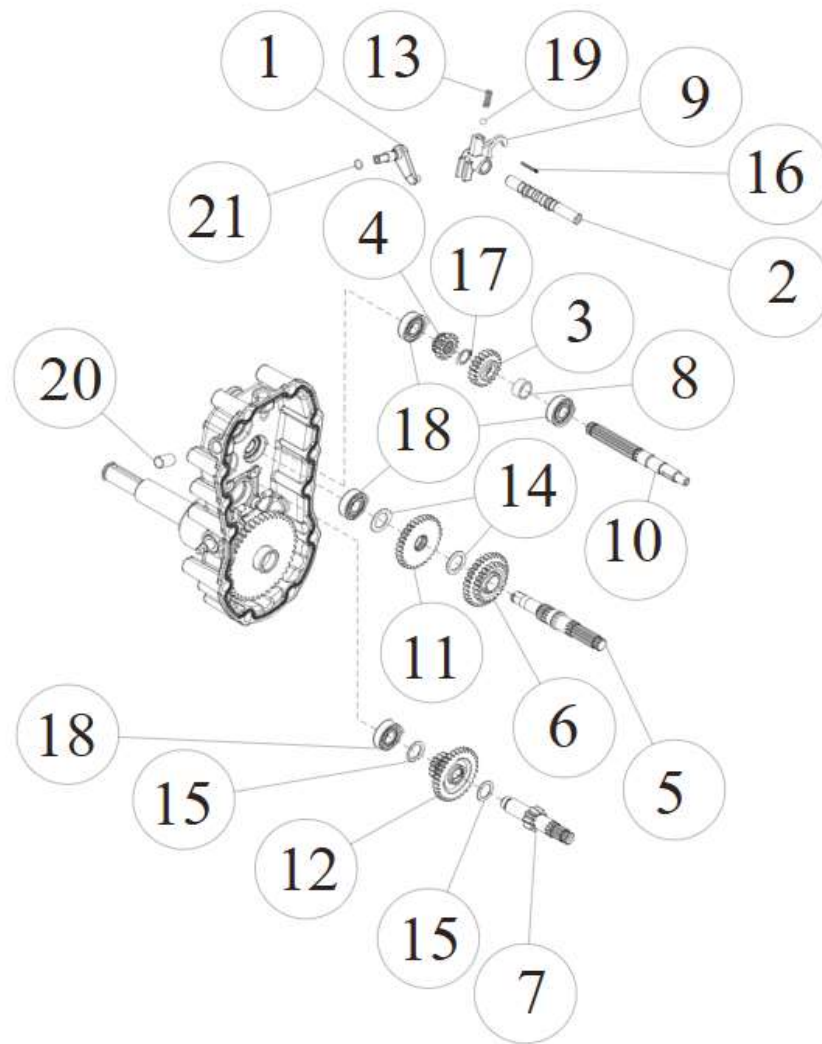

Ref.	Parts Number	Parts Name	Quantity	Remarks	R/P
1	80-1575-109-00	Swing Arm	1		
2	0223-00400	Shift Fork Shaft	1		
3	0223-00600	1st Shaft Gear 20T	1		
4	0223-00700	1st Shaft Shift Gear 14T	1		
5	0223-00800	2nd Shaft	1		
6	0223-01200	Back Gear CMP	1		
7	0223-01400	3rd Shaft	1		
8	0223-02400	Collar 11L	1		
9	0251-00300	Shift Folk	1		
10	0251-01100	Transmission 1st Shaft	1		
11	0251-01300	2nd Shaft Gear 32T	1		
12	0251-02100	3rd Shaft Gear 14T CMP	1		
13	0282-00400	Spring	1		
14	83-1310-371-00	Thrust Washer 20*30*1.0	2		
15	83-1830-368-00	Thrust Washer 18*26*1.0	2		
16	89-2120-200202	Split Pin 2*20	1		
17	89-2511-000160	Snap Ring (S16)	1		
18	89-3111-062024	Bearing 6202	4		
19	89-3410-075000	Steel Ball 7.5	1		
20	89-3510-012200	DU Bush 12.20	1		
21	89-5221-009000	O Ring P9	1		

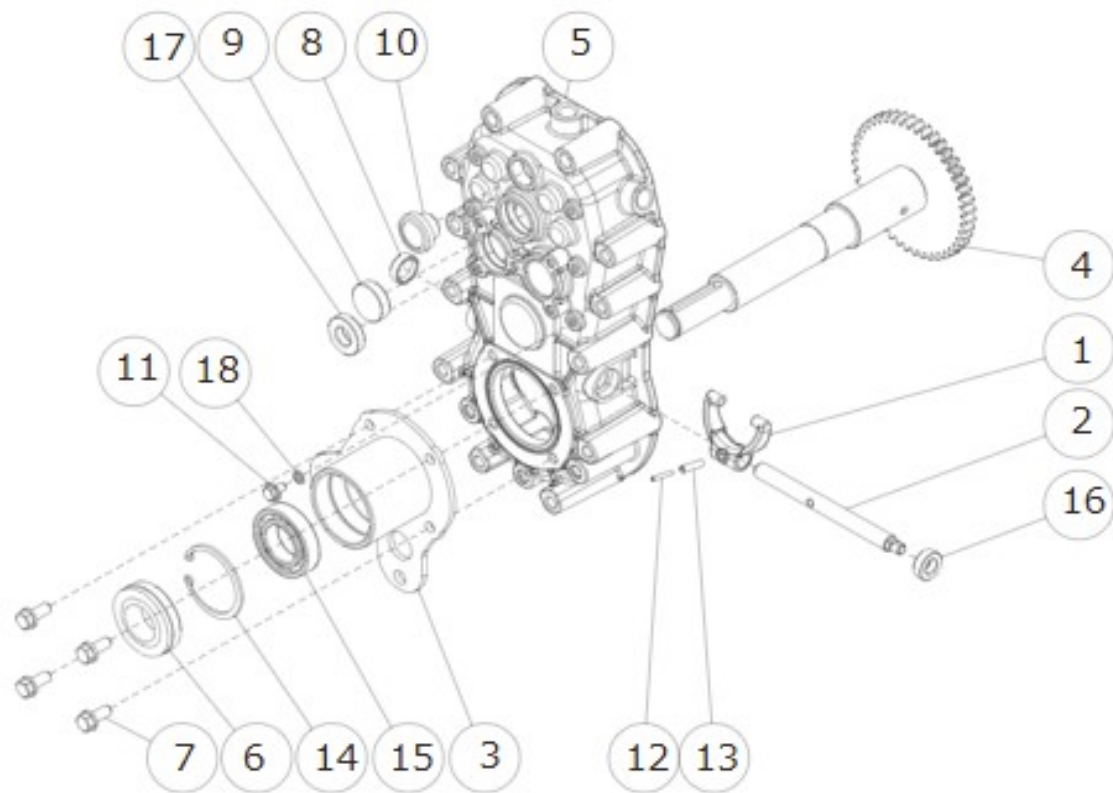

Ref.	Parts Number	Parts Name	Quantity	Remarks	R/P
1	80-1415-114-00	Side Clutch Fork	1		
2	80-1425-112-00	Driving Clutch Fork Shaft	1		
3	80-1565-155-0H	Shaft BB Case (L) (Metallic Grey)	1		
4	80-1614-146-10	Axle CMP	1		
5	0251-00110	Transmission Case (L)	1		
6	0297-08000	Oil Seal AP 35.55.16	1		
7	83-1415-127-00	Seal Bolt (SW) M8*20	4		
8	83-1415-671-00	Blind Cover 22	1		
9	83-1415-672-00	Blind Cover 30	1		
10	83-1517-685-00	Oil Cap 20	1		
11	89-1251-060102	Flange Hexagonal Bolt M6*10	1		
12	89-2111-030020	Spring Pin 3*20	1		
13	89-2111-050020	Spring Pin 5*20	1		
14	89-2512-000550	Snap Ring (R55)	1		
15	89-3111-060064	Bearing 6006	1		
16	89-5121-122207	Oil Seal UE 12.22.7	1		
17	89-5121-153007	Oil Seal UE 15.30.7	1		
18	89-5230-060000	Seal Washer 6	1		

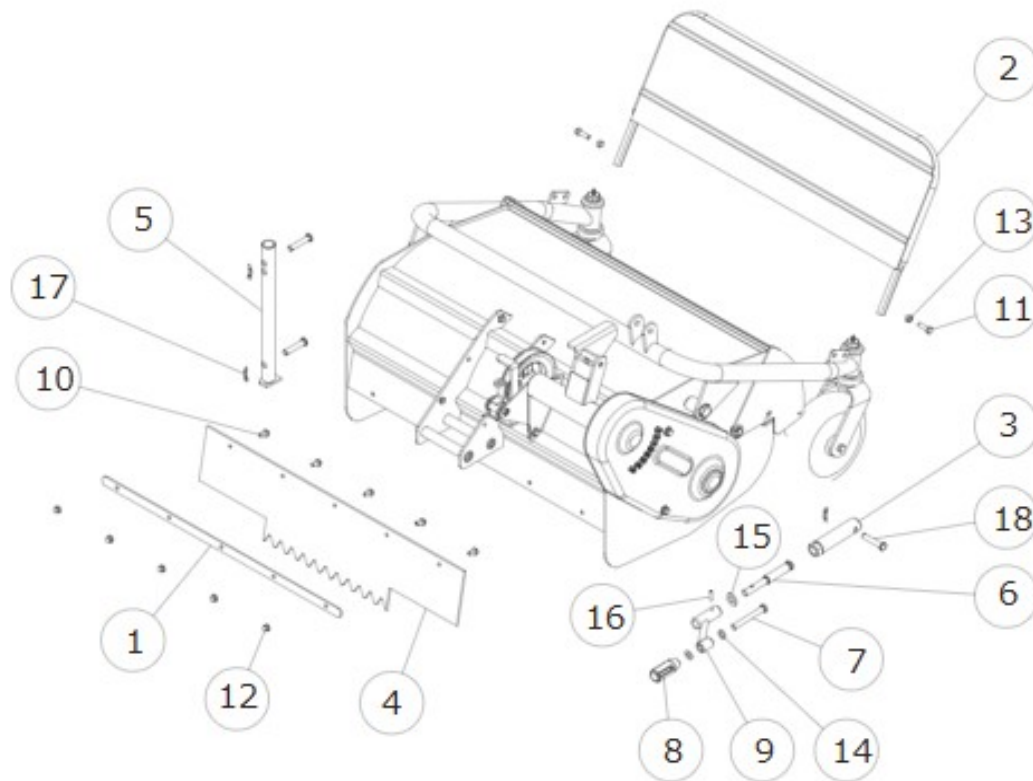

Ref.	Parts Number	Parts Name	Quantity	Remarks	R/P
1	80-1610-787-01	Flapper Holder (White)	1		
2	80-1613-733-1G	Safety Cover (Green)	1		
3	80-1614-742-1G	Height Adjusting Bolt Receiver (Green)	1		
4	80-1614-782-10	Rear Flapper	1		
5	0282-6020G	Cover Stand CMP (Green)	1		
6	0285-62400	Height Adjusting Bolt CMP	1		
7	0285-77000	Round Head Pin 10*80	1		
8	0334-75100	Lever Grip (Black) 10	1		
9	84-1723-739-00	Cutting Height Adjusting Handle	1		
10	89-1137-060152	Hexagonal Bolt (PW) M6*15	5		
11	89-1211-080252	Mini Hexagonal Bolt M8*25	2		
12	89-1581-060042	Flange Cap Nut M6	5		
13	89-1611-080042	Mini Hexagonal Nut M8	2		
14	89-1711-100002	Flat Washer 10*18*1.6	2		
15	89-1714-120002	Flat Washer 12	1		
16	89-2111-050022	Spring Pin 5*22	1		
17	89-2131-100002	Snap Pin 10	3		
18	89-2181-100502	Flat Head Pin 10*50	3		

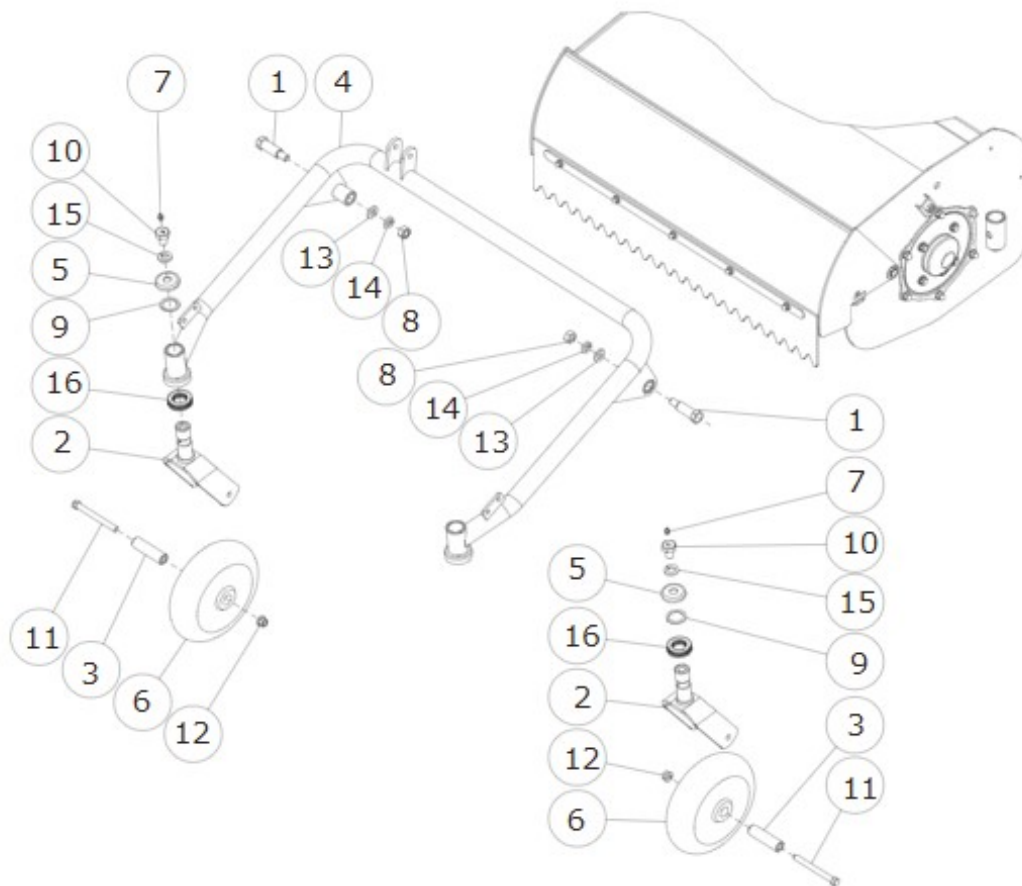

Ref.	Parts Number	Parts Name	Quantity	Remarks	R/P
1	80-1610-714-00	Front Arm Setting Shaft	2		
2	80-1614-725-2G	Front Wheel Fork (Green)	2		
3	0940-61300	Front Wheel Collar	2		
4	0211-6040G	Front Arm CMP (Green)	1		
5	0256-60700	Dust Cover	2		
6	0285-73100	Front Wheel (G200N-20)	2		
7	83-1415-975-00	Grease Nipple M6	2		
8	83-1610-192-00	Hexagonal Nut (slender) M12 P=1.25	2		
9	83-1783-376-00	Thrust Washer 25*34*1.0	2		
10	84-1783-791-00	Grease Nipple Bolt M14	2		
11	89-1211-100952	Mini Hexagonal Bolt M10*95	2		
12	89-1543-100002	Mini Hexagonal Nut (SW) M10	2		
13	89-1714-120002	Flat Washer 12	2		
14	89-1750-120002	Spring Washer 12	2		
15	89-1750-140002	Spring Washer 14	2		
16	89-3370-051105	Thrust Bearing 51105	2		

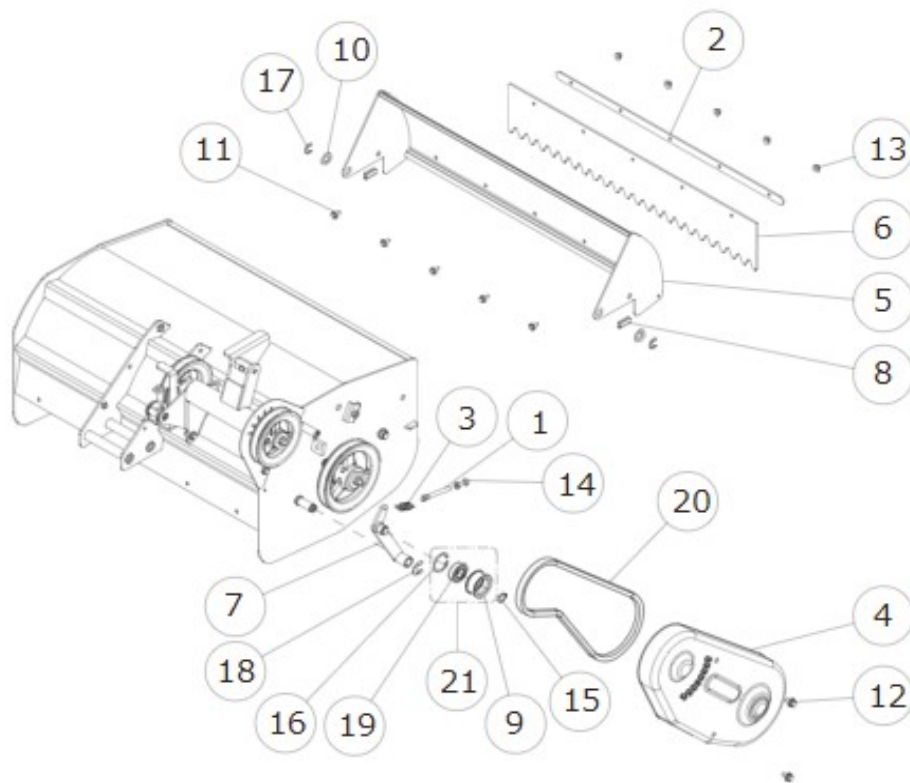

Ref.	Parts Number	Parts Name	Quantity	Remarks	R/P
1	80-1182-527-00	Tension Pulling Bolt	1		
2	80-1610-787-01	Flapper Holder (White)	1		
3	80-1614-315-00	Return Spring	1		
4	80-1614-694-11	Knife Belt Cover (White)	1		
5	80-1614-764-01	Front Cover CMP (White)	1		
6	80-1614-781-10	Front Flapper	1		
7	0211-63201	Front Tension Arm CMP (White)	1		
8	0285-66100	Rubber L30	2		
9	83-1032-765-00	Tension Pulley	1		
10	83-1630-342-00	Washer 16*26*2.3	2		
11	89-1137-060152	Hexagonal Bolt (PW) M6*15	5		
12	89-1233-080162	Mini Hexagonal Bolt (PWSW) M8*16	2		
13	89-1581-060042	Flange Cap Nut M6	5		
14	89-1611-080042	Mini Hexagonal Nut M8	2		
15	89-2511-000170	Snap Ring (S17)	1		
16	89-2512-000400	Snap Ring (R40)	1		
17	89-2521-000120	E Type Ring 12	2		
18	89-2521-000150	E Type Ring 15	1		
19	89-3115-062034	Bearing 6203 2RS	1		
20	89-6123-003900	V Belt LB-39	1		★★
21	83-1032-760-00	Tension Pulley Assy	1	Set of No.9,16,19	

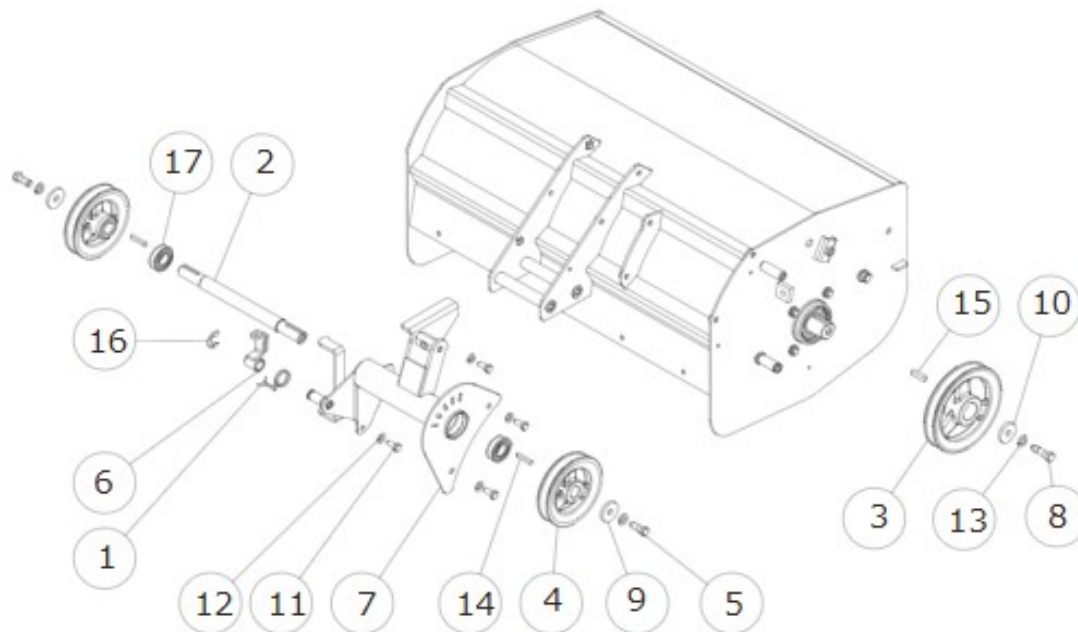

Ref.	Parts Number	Parts Name	Quantity	Remarks	R/P
1	80-1614-373-20	Knife Brake Spring	1		
2	80-1614-621-30	Supporter Shaft	1		
3	80-1614-634-21	Knife Pulley 155 (White)	1		
4	80-1614-636-00	Supporter Pulley	2		
5	0212-72120	Hexagonal Bolt (8T) M10*25 (Meck)	2		
6	0231-37101	Knife Brake (White)	1		
7	0285-6110G	Supporter Pipe CMP (Green)	1		
8	0335-70310	Hexagonal Bolt (8T) M10*35 (Meck)	1		
9	83-1610-321-00	Washer 10*36*4.5	2		
10	83-1610-322-00	Washer 10*36*6	1		
11	89-1213-080182	Mini Hexagonal Bolt (8T) M8*18	4		
12	89-1750-080002	Spring Washer 8	4		
13	89-1750-100002	Spring Washer 10	3		
14	89-2151-050350	Key 5*35 (half round)	2		
15	89-2151-070300	Key 7*30 (half round)	1		
16	89-2521-000150	E Type Ring 15	1		
17	89-3115-060044	Bearing 6004 2RS	2		

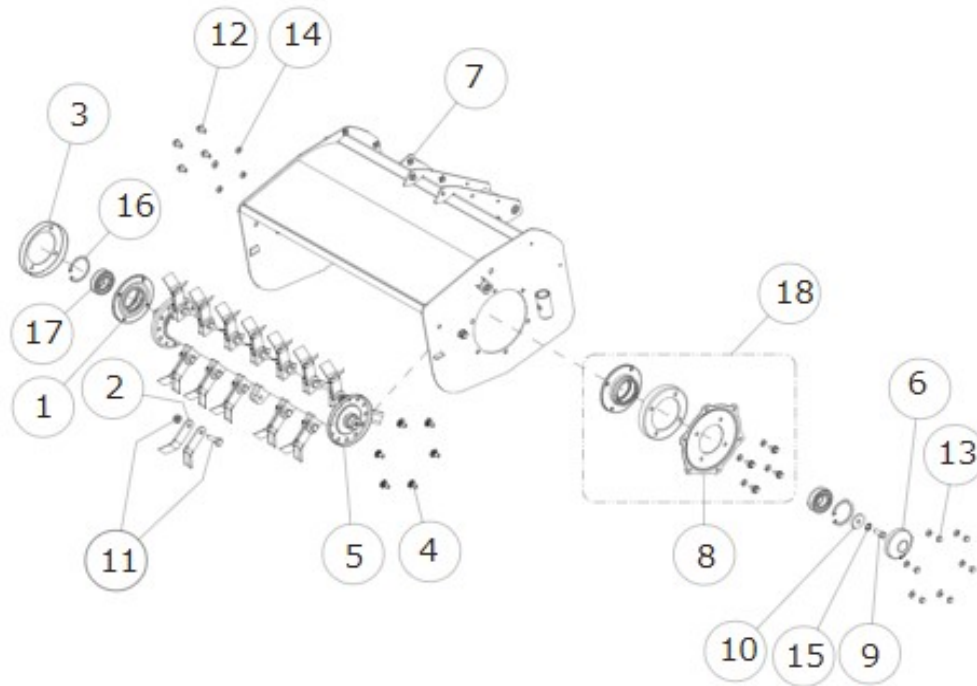

Ref.	Parts Number	Parts Name	Quantity	Remarks	R/P
1	80-1610-804-01	BB Case (White)	2		
2	80-1610-821-00	Hammer Knife Blade	38		★★
3	0285-60300	Dust Cover	2		
4	80-1614-705-00	Flat Head Bolt M8*18	6		
5	80-1614-800-00	Knife Drum ASSY	1	No. 2,11, Included	
6	80-1614-810-00	BB Case Cover	1		
7	0282-6010G	Rotary Cover CMP (Green)	1		
7	0285-60204	Rotary Cover (SUS) (Silver)	1	Stainless steel Used	
8	0285-6040G	Knife Shaft BB Case Holder (Green)	1		
9	0335-70210	Hexagonal Bolt (8T) M10*25 (Left screw)	1		
10	83-1610-321-00	Washer 10*36*4.5	1		
11	83-1610-835-00	Knife Setting Bolt Set	19		★★
12	89-1253-080162	Flange Mini Hexagonal Bolt (8T) M8*16	8		
13	89-1671-080042	Mini Cap Nut M8	6		
14	89-1750-080002	Spring Washer 8	14		
15	89-1812-100002	Toothed Washer (inside) 10	1		
16	89-2512-000620	Snap Ring (R62)	2		
17	89-3115-062064	Bearing 6206 2RS	2		
18	0285-6010G	Knife Shaft BB Case Set (Green)	1	1.3.8.12(4Pcs).14(4 pcs)	

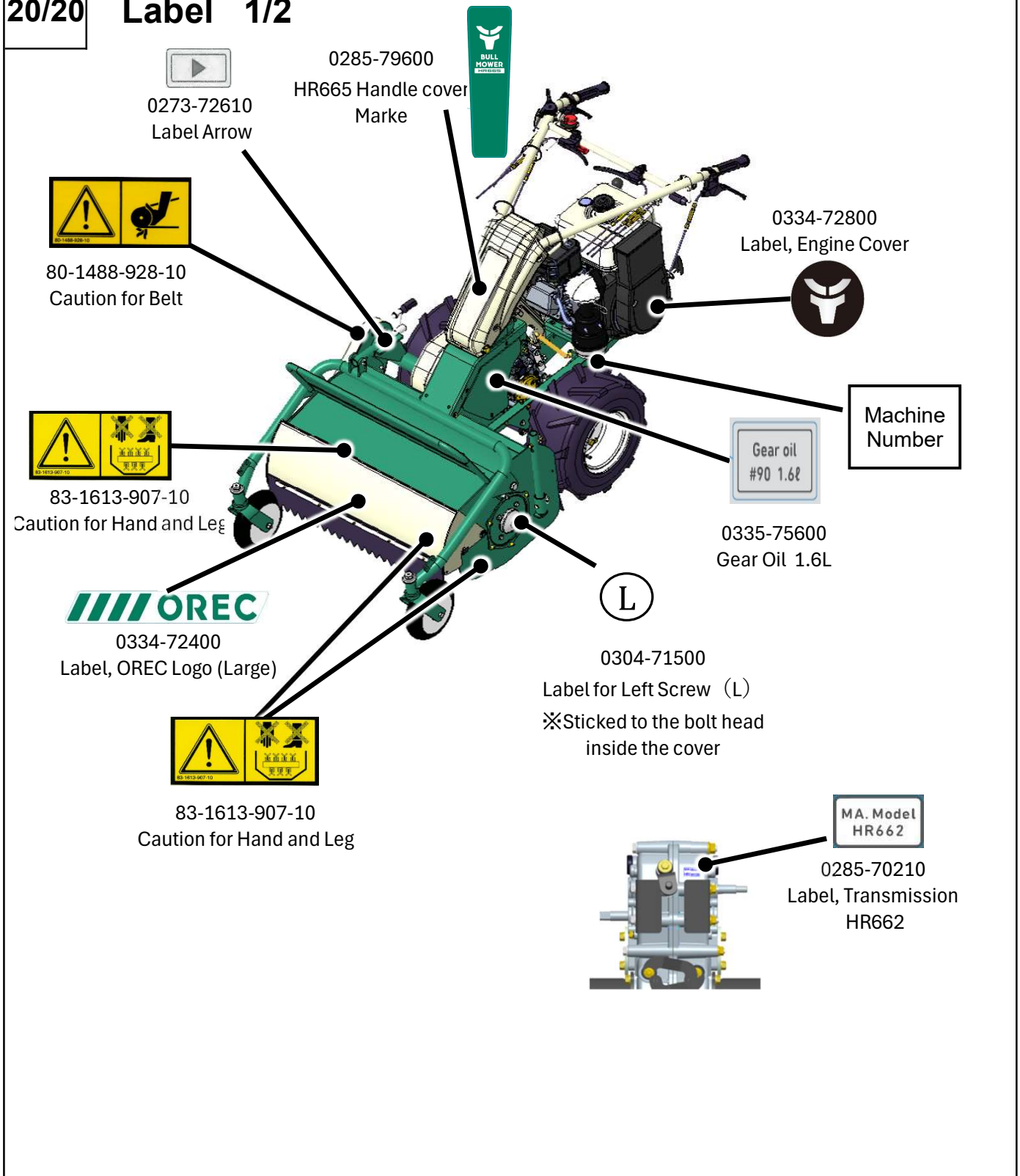

Ref.	Parts Number	Parts Name	Quantity	Remarks	R/P
	0285-79600	Label, HR665 Handle cover mark			
	0273-72610	Label, Arrow			
	80-1488-928-10	Label, Caution for Belt Involving			
	83-1613-907-10	Label, Caution for Hand and Leg			
	0334-72400	Label, OREC Logo (Large)			
	83-1613-907-10	Label, Caution for Hand and Leg			
	0304-71500	Label for Left Screw			
	0335-75600	Label, Gear Oil			
	0334-72800	Label, Engine Cover			
	0285-70210	Label, Transmission HR662			

